



**METROPOLITAN
TRANSPORTATION
COMMISSION**

Joseph P. Bort MetroCenter
101 Eighth Street
Oakland, CA 94607-4700
TEL 510.817.5700
TTY/TDD 510.817.5769
FAX 510.817.5848
E-MAIL info@mtc.ca.gov
WEB www.mtc.ca.gov

Air Quality Conformity Task Force

Metropolitan Transportation Commission
Joseph P. Bort MetroCenter
Fishbowl Conference Room – 3rd Floor
101 Eighth Street, Oakland

Conference Call Number: 888-273-3658 (Access Code: 9427202)

**Thursday, March 24, 2016
9:30 a.m. –11:00 a.m.**

AGENDA

1. Welcome and Introductions
2. PM_{2.5} Project Conformity Interagency Consultations
 - a. Consultation to Determine Project of Air Quality Concern Status
 - i. Conde Lane/Johnson Street Pedestrian Improvements Project
 - ii. 7th Street West Oakland Transit Village Phase II Project
 - b. Confirm Projects Are Exempt from PM_{2.5} Conformity
 - i. Projects Exempt Under 40 CFR 93.126 – Not of Air Quality Concern
3. Projects with Regional Air Quality Conformity Concerns
 - a. Review of the Regional Conformity Status for New and Revised Projects us
3a_Regional_AQ_Conformity_Review.pdf
3a_Attachment-A_List_of_Proposed_New_Projects_3-24-16.pdf
4. Consent Calendar
 - a. February 25, 2016 Air Quality Conformity Task Force Meeting Summary
5. Other Items

Next Meeting: April 28, 2016

MTC Staff Liaison: Harold Brazil hbrazil@mtc.ca.gov



METROPOLITAN
TRANSPORTATION
COMMISSION

Joseph P. Bort MetroCenter
101 Eighth Street
Oakland, CA 94607-4700
TEL 510.817.5700
TDD/TTY 510.817.5769
FAX 510.817.5848
E-MAIL info@mtc.ca.gov
WEB www.mtc.ca.gov

Memorandum

TO: Air Quality Conformity Task Force

DATE: March 10, 2016

FR: Harold Brazil

W. I.

RE: PM_{2.5} Project Conformity Interagency Consultation

Project sponsors representing two projects, seek interagency consultation from the Air Quality Conformity Task Force (AQCTF) at today's meeting and the projects are as follows:

No.	Project Sponsor	Project Title
1	Town of Windsor	Conde Lane/Johnson Street Pedestrian Improvements Project
2	City of Oakland	7th Street West Oakland Transit Village Phase II Project

2ai_Conde_Lane_Johnson_Street_Pedestrian_Improvements_Project_Assessment_Form.pdf (for the Conde Lane/Johnson Street Pedestrian Improvements project)

2aii_7th_Street_West_Oakland_Transit_Village_Phase_II_Project_Assessment_Form.pdf (for the 7th Street West Oakland Transit Village Phase II project)

MTC also requests the review and concurrence from the Task Force on projects that project sponsors have identified as exempt and likely not to be a POAQC. **2b_Exempt List 031016.pdf** lists exempt projects under 40 CFR 93.126

PM_{2.5} Project Assessment Form for Interagency Consultation

RTIP ID# <i>(required)</i> 240651					
TIP ID# SON130012					
Air Quality Conformity Task Force Consideration Date April 15, 2015					
Project Description: <i>The Conde Lane/Johnson Street Pedestrian Improvement Project will realign the all-way stop-controlled intersection to eliminate the need for intersection controls, and install sidewalk where it is missing and new crosswalks, including an enhanced crosswalk. These improvements will significantly decrease the delay associated with existing Level of Service (LOS) D operations, and also provide pedestrian safety improvements associated with closing a gap in the sidewalk in the intersection, add a pedestrian-activated crosswalk warning light, also known as a Rectangular Rapid Flashing Beacon (RRFB) at one new intersection crosswalk, and construct curb extensions.</i>					
Type of Project: <i>Intersection Pedestrian Improvements</i>					
County Sonoma	Narrative Location/Route & Post Miles: <i>The work area covers all three legs of the intersection. It extends approximately; 450 feet east, 110 feet west, and 220 feet north of the center of the intersection. Work in this area includes: remove and replace asphaltic pavement (including the associated roadway excavation), remove and replace curb and gutter, remove and replace sidewalk, add sidewalk to the south side of Conde Lane at the intersection, remove and replace driveway, and remove and replace thermoplastic striping and pavement markings. Items of work include; pavement markings, reflective pavement markers, roadside signs, street and safety lights, and a Rapid Rectangular Flashing Beacon (RRFB) pedestrian crossing signal system with pedestrian push buttons and post mounted flashing beacons. The existing pedestrian ramps will be removed and replaced as needed, and a surface treatment will be applied encompassing the entire disturbed area after the surface and underground improvements are complete and prior to placing pavement markings and stripes.</i> Caltrans Projects – EA# n/a				
Lead Agency: <i>Town of Windsor</i>					
Contact Person <i>Alejandro Perez, P.E.</i>	Phone# <i>(707) 838-5318</i>	Fax# <i>(707) 838-5300</i>	Email <i>aperez@townofwindsor.com</i>		
Federal Action for which Project-Level PM Conformity is Needed <i>(check appropriate box)</i>					
<input checked="" type="checkbox"/>	Categorical Exclusion (NEPA)	EA or Draft EIS	FONSI or Final EIS	PS&E or Construction	Other
Scheduled Date of Federal Action:					
NEPA Delegation – Project Type <i>(check appropriate box)</i>					
		<input checked="" type="checkbox"/>	Section 326 –Categorical Exclusion	Section 327 – Non-Categorical Exclusion	
Current Programming Dates <i>(as appropriate)</i>					
	PE/Environmental	ENG	ROW	CON	
Start	<i>02/15</i>	<i>01/16</i>	<i>n/a</i>	<i>06/16</i>	
End	<i>12/15</i>	<i>02/16</i>	<i>n/a</i>	<i>09/16</i>	

Project Assessment Form for PM_{2.5} Interagency Consultation

Project Purpose and Need (Summary):

This intersection is located within the Windsor Priority Development Area (PDA). The project location was included in the Town of Windsor Pedestrian Safety Assessment which was funded by a grant from the California Office of Traffic Safety and conducted by the Technology Transfer Program of the Institute of Transportation Studies at the University of California, Berkeley in 2012. This study identified high potential conflict areas between pedestrians and drivers at this intersection and recommended pedestrian safety enhancements, particularly for Windsor Elementary School students walking in the area, with the improvements included on this project.

Surrounding Land Use/Traffic Generators:

Conde Lane is identified as a "Cross-Town" (major arterial) street by the Town of Windsor, is on public bus routes, is a truck route, serves the downtown shopping, recreational areas, is a major north-south route to and from the inter-modal transit facility located at the intersection with Windsor River Road, and is the access point for Windsor Elementary School. Johnson Street is a local street on a bus route and serves adjacent multi-family and condominium residential. Improvements to traffic flow will help reduce diesel emissions on both streets.

Brief summary of assumptions and methodology used for conducting analysis:

In 2008 the Traffic Impact Mitigation Fee Program (TIMF) identified this intersection as needing a traffic signal or roundabout under existing conditions, and the Bell Village Traffic Impact Study and the Station Area/Downtown Specific Plan also noted the need for capacity improvements at this time. Additionally, after receiving a low pedestrian safety ranking from the California Office of Traffic Safety in 2010, the Town of Windsor requested that the Institute of Transportation Studies at University of California, Berkeley conduct a Pedestrian Safety Assessment (PSA). The PSA report was published in 2012 and recommended sidewalk and crosswalk improvements at this intersection to enhance pedestrian safety.

The existing Conde Lane/Johnson Street tee-intersection has all-way stop controls which provide crossing safety for pedestrians, though the lack of sidewalk on the south side of the intersection prevents them from bypassing the potential conflict areas. Capacity was evaluated with recently collected data and it was determined that the intersection is currently operating at a LOS D, which is expected to deteriorate to LOS F operations under worst-case build out conditions using the "All-Way Stop-Controlled" intersection capacity method published in the Highway Capacity Manual, Transportation Research Board, 2010 (HCM 2010).

The project would realign Conde Lane to curve rather than intersect at a 90-degree turn, with access to Johnson Street restricted to right-turns in and out. This realignment will enable the removal of stop signs on Conde Lane, with a LOS A operations expected under the worst case buildout scenario according to the "Two-Way Stop-Controlled" methodology of HCM 2010. A sidewalk would be built to eliminate the existing gap on the south side of Conde Lane and a median added to serve as a pedestrian refuge island within a new RRFB-enhanced crosswalk and also to restrict left turns.

Opening Year: If facility is a highway or street, Build and No Build LOS, AADT, % and # trucks, truck AADT of proposed facility .

Not applicable; this project is not a highway or street, it is an intersection improvement.

RTP Horizon Year / Design Year: If facility is a highway or street, Build and No Build LOS, AADT, % and # trucks, truck AADT of proposed facility.

Not applicable; this project is not a highway or street, it is an intersection improvement.

PM_{2.5} Project Assessment Form for Interagency Consultation

Opening Year: If facility is an interchange(s) or intersection(s), Build and No Build cross-street AADT, % and # trucks, truck AADT.

No Build Opening Year (2016-17) values are expected to be as follows:

Cross Street: Johnson Street AADT =600, 0.25% trucks or 2 trucks AADT.

Major Street: Conde Lane AADT = 7,340, including 2.0 % trucks, or 147 trucks AADT.

Build Opening Year (2016-17) values are expected to be as follows:

Cross Street: Johnson Street AADT =450, 0.25% trucks or 1 truck AADT.

Major Street: Conde Lane AADT = 7,340, including 2.0 % trucks, or 147 trucks AADT.

RTP Horizon Year / Design Year: If facility is an interchange (s) or intersection(s), Build and No Build cross-street AADT, % and # trucks, truck AADT.

No Build Project Horizon Year/Design Year (2040) values are expected to be as follows:

Cross Street: Johnson Street AADT =1,200, 0.25% trucks or 3 trucks AADT.

Major Street: Conde Lane AADT = 14,680, including 2.0 % trucks, or 294 trucks AADT.

Build Project Horizon Year/Design Year (2040) values are expected to be as follows:

Cross Street: Johnson Street AADT =900, 0.25% trucks or 2 trucks AADT.

Major Street: Conde Lane AADT = 14,680, including 2.0 % trucks, or 294 trucks AADT

Opening Year: If facility is a bus, rail or intermodal facility/terminal/transfer point, # of bus arrivals for Build and No Build, % and # of bus arrivals will be diesel buses

Not applicable; this project is not a bus, rail or intermodal facility, it is an intersection improvement.

RTP Horizon Year / Design Year: If facility is a bus, rail or intermodal facility/terminal/transfer point, # of bus arrivals for Build and No Build, % and # of bus arrivals will be diesel buses

Not applicable; this project is not a bus, rail or intermodal facility, it is an intersection improvement.

Describe potential traffic redistribution effects of congestion relief (impact on other facilities)

The project has the potential to increase the traffic on Windsor River Road because the trips that now make a left turn on and off Johnson Street at Conde Lane will be prohibited and will likely use the next closest alternate street, Windsor River Road, which is one block to the north. However, the estimated daily traffic volume on Johnson Street is 600 vpd, of which, approximately one-quarter, or 150 vehicles will be redirected one block. Windsor River Road has an estimated AADT = 13,210, so the 150 vehicles redirected by the project represents slightly more than one percent.

Project Assessment Form for PM_{2.5} Interagency Consultation

Comments/Explanation/Details *(please be brief)*

Attachments:

Location Map

Figure showing surrounding land uses

Site Plan

Peak Hour Performance – Option 1 is the current plan

Average Daily Traffic (ADT), Truck Volumes and Traffic Studies

In 2015 the Town of Windsor began the process of updating the Windsor General Plan, and the Transportation Element evaluation of existing conditions was published in May 2015. It includes estimated truck percentages and associated truck routes, and LOS evaluations and methodology descriptions included in answers to some of the questions in this form. Following is a link to this document on the Town of Windsor website:

http://www.windsor2040.com/wp-content/uploads/2015/04/05_PRD_TOWGPU_BR_Ch5_TransportationandMobility_2015_4-27.pdf

2012 Average Daily Traffic (ADT) information is available on the following Town of Windsor website: <http://www.ci.windsor.ca.us/DocumentCenter/View/14318>

Additionally, a traffic study was completed to provide Town Council information to be used to select specific intersection controls, and the study included “future conditions” intersection LOS calculations, with and without the project (Build and No Build). A copy of this report is attached.

Summary of how criteria of air quality concern does not apply to this project

PM_{2.5} Project Assessment Form for Interagency Consultation

Summary - Not a Project of Air Quality Concern (40 CFR 93.123(b)(1))

- (i) *New or expanded highway projects with significant number/increase in diesel vehicles?*
 - Not a new or expanded highway project
 - No change in traffic volume or truck percentages at intersection
 -
- (ii) *Affects intersections at LOS D, E, or F with a significant number of diesel vehicles?*
 - Diesel vehicles represent 2% of intersection traffic volume
 - Intersection at LOS D improves and delay decreases (existing condition)
 - No project changes to land use that would affect diesel traffic percentage
 -
- (iii) *New bus and rail terminals and transfer points?—Not Applicable*
- (iv) *Expanded bus and rail terminals and transfer points?—Not Applicable*
- (v) *Affects areas identified in PM₁₀ or PM_{2.5} implementation plan as site of violation?*
 - No state implementation plan for PM_{2.5}
 - The project does not affect areas identified in PM₁₀ or PM_{2.5} implementation plan as site of violation
 - Also, the project area is not identified in the plans as an area of potential violation.

Conde Lane - Johnson Street Traffic Signal and Pedestrian Enhancement 2012 One Bay Area Grant (OBAG) Application

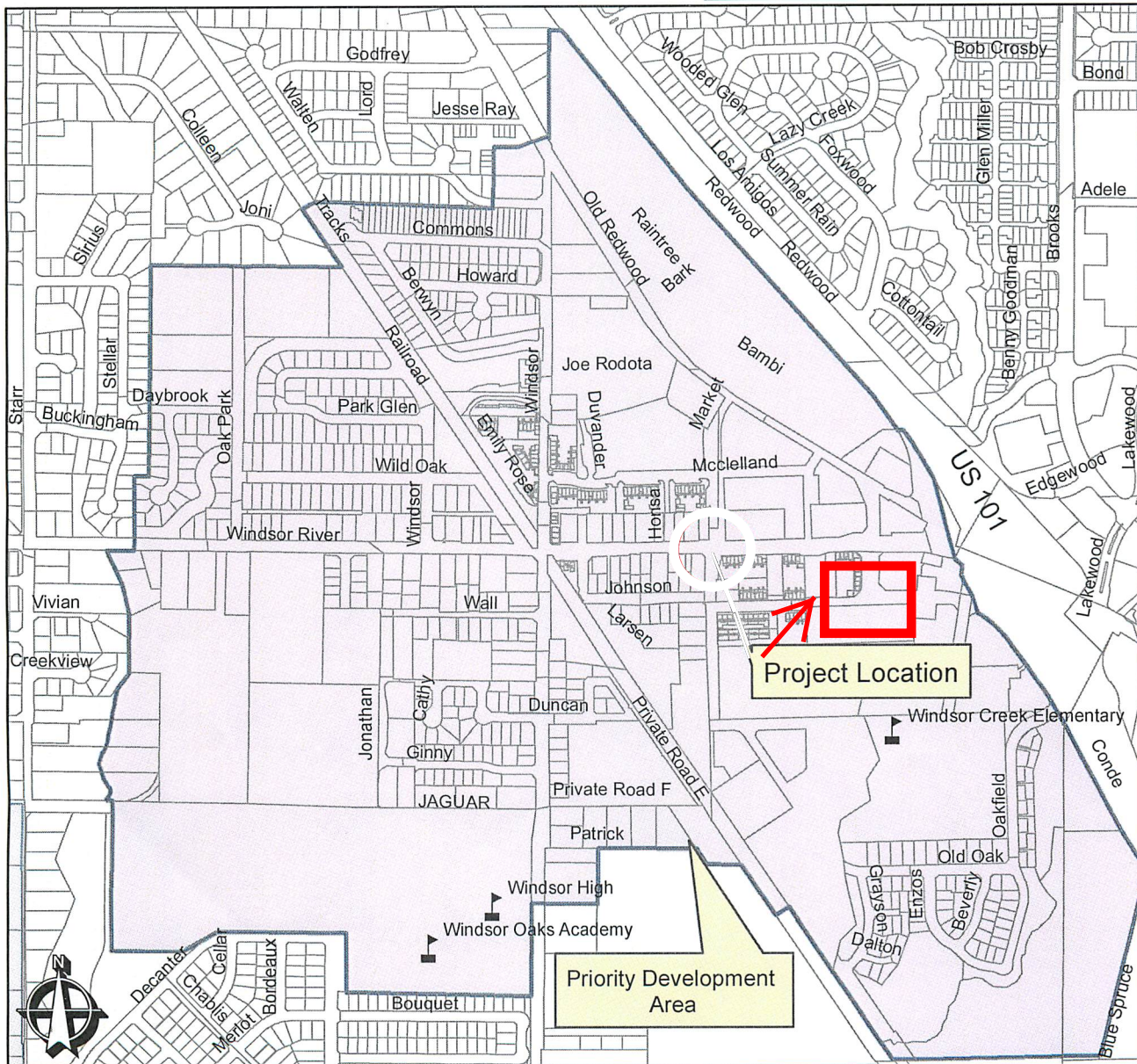
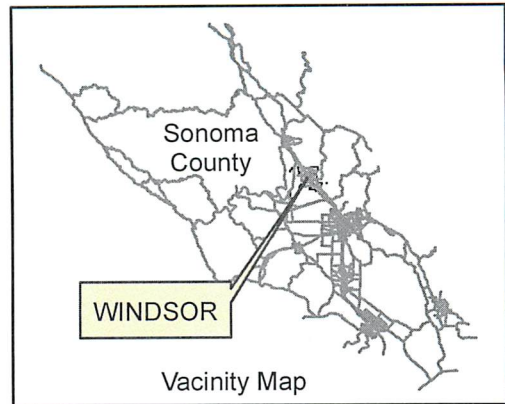

Project Location Map



TOWN OF WINDSOR	CALCULATED/DESIGNED BY		REVISOR	
	CHECKED BY		DATE	

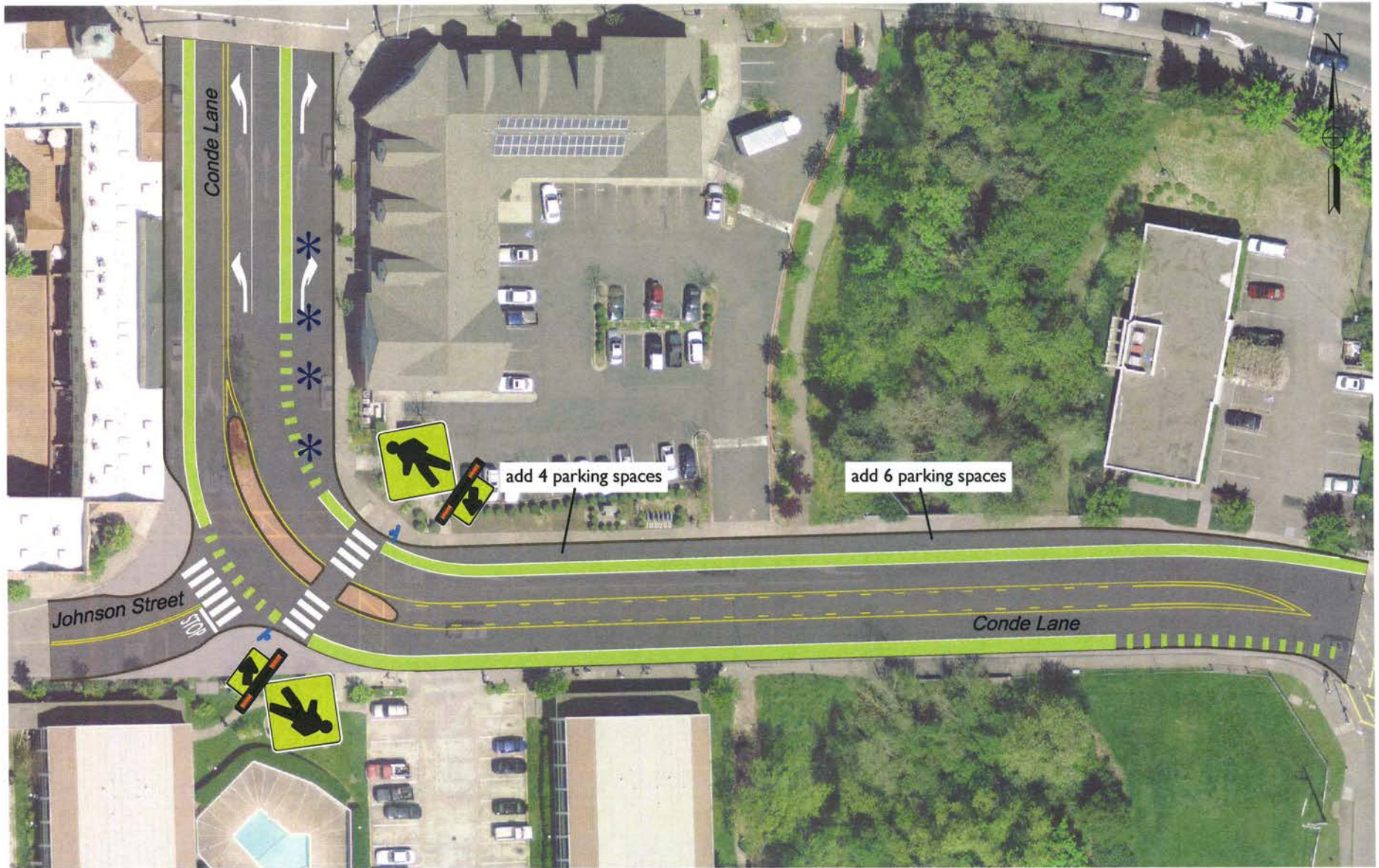

CONDE LANE/JOHNSON STREET

* parking space impact (4 spaces removed)
net increase of 6 spaces after adding 10 on Conde

REALIGNMENT OPTION
1" = 60'



MARKET STREET

RETAIL
OFFICE

McDONALDS

OLD REDWOOD
HIGHWAY

GAS
STATION

WINDSOR RIVER ROAD

OLD REDWOOD HWY.

LIVE/
WORK

LIVE/
WORK

RETAIL/
OFFICE

RETAIL/
OFFICE

CONDE
LANE

OFFICE

HIGHWAY-101

SFU

SFU

SFU

LIVE/
WORK

LIVE/
WORK

SITE

CONDE LANE

BELL ROAD

JOHNSON STREET

DUPLEX

LIVE/
WORK

APARTMENTS

HOTEL

SFU

APARTMENTS

BOWLING
ALLEY



NORTH

WINDSOR ELEMENTARY
SCHOOL

LAND USE MAP

SURROUNDING ZONING IS "MIXED USE" WHICH IS EITHER
"TOWN CENTER" OR "MED-HIGH DENSITY RESIDENTIAL"

Conde Lane/Johnson Street Intersection Peak Hour Performance

	Existing Configuration	Option 1 Realignment with RRFB	Option 2 Signal	Option 3 Roundabout
Safety	Adequate	Excellent	Good	Excellent
LOS Existing	LOS D	LOS A	LOS A	LOS A
LOS Future	LOS F	LOS A	LOS C	LOS A
Vehicle Queuing Future	Poor	Good	Good	Good
Emissions Future	Unchanged	Significant Decrease	Some Decrease	Significant Decrease
Geometric Fit	Good	Good	Good	Major Impact to Apartments
Local Access	Unchanged	Restricted Left-Turns to/from Johnson	Unchanged	Impacts One Apartment Driveway

RRFB=Rectangular Rapid-Flashing Beacon; LOS=Level of Service

Conde Lane/Johnson Street (for simplification results reflect the worst-case peak hour of the day)

Application of Criteria for a Project of Air Quality Concern

Project Title: 7th Street West Oakland Transit Village Phase II

Project Summary for Air Quality Conformity Task Force Meeting:

Description

- Project will implement a road diet and reduce the number of travel lanes in each direction.
- There will be no change in traffic volumes and no change in LOS.
- Project will enhance bicycle and pedestrian features in the area to promote mode shifts.

Background

- NEPA process for Categorical Exemption/Initial Study/Environmental Assessment (IS/EA) almost complete
- No comments received on air quality thus far
- Seeking air quality conformity determination

Not a Project of Air Quality Concern (40 CFR 93.123(b)(1))

(i) New or expanded highway projects with significant number/increase in diesel vehicles?

- Not a new or expanded highway project
- Road diet with no change in anticipated volume of traffic or change in number of trucks.
- No change in traffic volume or truck percentages

(ii) Affects intersections at LOS D, E, or F with a significant number of diesel vehicles?

- Diesel vehicles represent less than 11% of intersection traffic volume
- Intersections at LOS B
- No project changes to land use that would affect diesel traffic percentage

(iii) New bus and rail terminals and transfer points?—Not Applicable

(iv) Expanded bus and rail terminals and transfer points?—Not Applicable

(v) Affects areas identified in PM₁₀ or PM_{2.5} implementation plan as site of violation?

- While the area has been designated as a potential area of concern, this project does not substantially change the traffic conditions and promotes bicycle and pedestrian modes of transportation which is used to encourage mode shifts.
- SFBAAB has been given a clean data determination and is awaiting submission and approval of plans to change the attainment designation.
- Therefore, not identified in plan as an area of potential violation

RTIP ID# 240381				
TIP ID# ALA130014				
Air Quality Conformity Task Force Consideration Date				
Project Description <i>(clearly describe project)</i> The project is located on 7 th Street from Peralta Street to Wood Street in Oakland, California. The project will include the reduction of the existing 4-lane roadway to a 2-lane roadway to accommodate bicycle lanes and parking. The project will include pavement grinding and repaving, construction of bulb-outs, curb and gutter, installation of pedestrian lights and American Disability Act (ADA)-compliant curb ramp, widening of sidewalks and crosswalks, removal and planting of trees, upgrade and relocation of traffic signals and drainage inlets, and placement of street furnishing (bike racks, trash cans, etc).				
Type of Project: Road diet on 7 th Street. Bike and Pedestrian improvements to neighborhood arterial streets.				
County Alameda	<i>Narrative Location/Route & Postmiles</i> Within City of Oakland along 7 th street between Peralta Street and Wood Street. Caltrans Projects – EA#			
Lead Agency:				
<i>Contact Person</i> Mohammad Barati	<i>Phone#</i> 510-238-7280	<i>Fax#</i>	<i>Email</i> mbarati@oaklandnet.com	
Federal Action for which Project-Level PM Conformity is Needed <i>(check appropriate box)</i>				
<input checked="" type="checkbox"/> <i>Categorical Exclusion (NEPA)</i>	<input type="checkbox"/> EA or Draft EIS	<input type="checkbox"/> FONSI or Final EIS	<input type="checkbox"/> PS&E or Construction	<input type="checkbox"/> <i>Other</i>
Scheduled Date of Federal Action:				
NEPA Delegation – Project Type <i>(check appropriate box)</i>				
<input type="checkbox"/>	<input checked="" type="checkbox"/> Section 326 – Categorical Exclusion	<input type="checkbox"/> Section 327 – Non-Categorical Exclusion		
Current Programming Dates <i>(as appropriate)</i>				
	PE/Environmental	ENG	ROW	CON
Start				2016
End				2017

Project Purpose and Need (Summary): *(please be brief)*

Safety improvements to benefit pedestrians and bicyclists on neighborhood streets in West Oakland.

Road Diet on 7th Street

Bulb outs

Bike lanes

Cross walk improvements

Surrounding Land Use/Traffic Generators *(especially effect on diesel traffic)*

Immediate surrounds are largely residential/neighborhood commercial with mix of industrial warehouses nearby. Access to I-880 is nearby. The Port of Oakland is located across from I-880, but 7th street in this area is not a truck route.

Brief summary of assumptions and methodology used for conducting analysis

Section 93.116(a) of 40 Code of Federal Regulations (CFR) states that a Federal Highway Administration/Federal Transit Agency (FHWA/FTA) project must not cause or contribute to any new localized PM_{2.5} violations or increase the frequency or severity of any existing PM₁₀ and PM_{2.5} violations in non-attainment or maintenance areas. The regulations further state that projects may satisfy this requirement without an analysis of their potential to create PM hot-spots provided they do not meet the following criteria:

- 1) *New or expanded highway projects that have a significant number of or significant increase in diesel vehicles (significant number is defined as greater than 125,000 Annual Average Daily Traffic (AADT) and 8% or more of such AADT is diesel truck traffic, or in practice 10,000 truck AADT or more regardless of total AADT; significant increase is defined in practice as a 10% increase in heavy duty truck traffic);*

- 2) *Projects affecting intersections that are at a Level of Service D, E, F, with a significant number of diesel vehicles, or that that will change to Level of Service D, E, or F because of increased traffic volumes from a significant number of diesel vehicles related to the project;*

- 3) *New bus and rail terminals and transfer points that have a significant number of diesel vehicles congregating at a single location;*

- 4) *Expanded bus and rail terminals and transfer points that significantly increase the number of diesel vehicles congregating at a single location; or*

- 5) *Projects in or affecting locations, areas, or categories of sites which are identified in the PM_{2.5} or PM₁₀ implementation plan or implementation plan submission, as appropriate, as sites of possible violation.*

The project does not meet any of these criteria as outlined below:

The project is a road diet project and does not widen or create additional automobile travel lanes. The travel lanes are reduced on 7th street from 4 lanes to 2 lanes and include class II bicycle lanes. There will be no added or expanded bus or rail stations. No increase in truck traffic is anticipated due to the project changes. Based on available traffic data estimates, the project is below criteria for Project of Air Quality Concern (POAQC).

Traffic data has been assessed for opening and horizon years for the build and no-build condition for the 7th Street and Peralta Street intersection and the 7th Street and Wood Street intersection. These traffic data show that the project will not result in increased traffic based on the opening or horizon year models. There will be no increase in the percentage of truck traffic and the Level of Service (LOS) will remain the same.

The truck volume is between 6-11% of the peak hour traffic with total number of trucks between 46-85 in the opening year and between 11-100 in the horizon year. There is no increase in truck traffic seen in the 'build' to 'no build' conditions. Annual Average Daily Traffic (AADT) would be about 7,000 vehicles per day at these intersections based on daily volume measurements from 2012 and extrapolation of turning movement counts in 2015. Given the low number of truck trips during the peak hour, it is unlikely that total truck trips exceed 10,000 trucks per day and the total daily trips would be substantially less than 125,000. Therefore criteria 1 is not met.

The LOS is B and does not change due to the project. Therefore criteria 2 is not met.

Criteria 3 and 4 do not apply to this project since the project does not involve bus or rail terminals or transfer points that have a large number of diesel vehicles at one location.

Regarding criteria 5, the project is located in the West Oakland area which BAAQMD has designated as a CARE community and has conducted monitoring studies on air quality in this area. While the area has been designated as a potential area of concern, this project does not substantially change the traffic conditions and promotes bicycle and pedestrian modes of transportation which is used to encourage mode shifts. In addition, the SFBAAB has been given a clean data determination and is awaiting submission and approval of plans to change the attainment designation.

Since none of the criteria apply, the project is not a POAQC.

Opening Year: If facility is a highway or street, Build and No Build LOS, AADT, % and # trucks, truck AADT of proposed facility

Using a kd of 0.08-0.10 to convert peak hour to AADT.

Street Intersection	Peak Hour	No Build AADT	LOS	Trucks	Peak AADT	%
7th/Peralta	831	8310-10388	B	46	460-575	6%
7th/Wood	789	7890-9863	B	85	850-1063	11%

Build

Peak Hour	AADT	LOS	Trucks	Peak AADT	%
831	8310-10388	B	46	460-575	6%
789	7890-9863	B	85	850-1063	11%

**RTP Horizon Year / Design Year: If facility is a highway or street, Build and No Build LOS, AADT, % and # trucks, truck AADT of proposed facility
RTP Horizon: 2035/2040**

Using a kd of 0.08-0.10 to convert peak hour to AADT.

Street Intersection	Peak Hour	No Build AADT	LOS	Trucks	Peak AADT	%
7th/Peralta	967	9670-12088	B	110	1100-1375	11%
7th/Wood	1055	10550-13188	B	100	1000-1250	9%

Build

Peak Hour	AADT	LOS	Trucks	Peak AADT	%
1281	12810-16013	B	56	560-700	4%
1010	10100-12625	B	50	500-625	5%

Opening Year: If facility is an interchange(s) or intersection(s), Build and No Build cross-street AADT, % and # trucks, truck AADT

See above

RTP Horizon Year / Design Year: If facility is an interchange (s) or intersection(s), Build and No Build cross-street AADT, % and # trucks, truck AADT

See above

Opening Year: If facility is a bus, rail or intermodal facility/terminal/transfer point, # of bus arrivals for Build and No Build, % and # of bus arrivals will be diesel buses

Not a bus, rail or intermodal facility

RTP Horizon Year / Design Year: If facility is a bus, rail or intermodal facility/terminal/transfer point, # of bus arrivals for Build and No Build, % and # of bus arrivals will be diesel buses

Not a bus, rail or intermodal facility

Describe potential traffic redistribution effects of congestion relief *(impact on other facilities)*

This project has minimal effects on traffic. This is a road diet on 7th street and is anticipated to have minimal redistributive effect since traffic is light for the size of the roadway.

Comments/Explanation/Details (please be brief)

The project provides traffic calming elements to neighborhood arterial street in West Oakland. 7th Street will have a road diet from 2 lanes in each direction to 1 lane in each direction. The intent of the improvements is to increase the safe use of the streets for pedestrians and bicyclists while encouraging traffic to stay at the speed limit. Since the street is not highly congested, the improvements will have minimal impacts on auto congestion as evidenced by no change in LOS of B.

See attached intersection counts and site plans.

7th Street West Oakland Transit Village Streetscape Phase II: Project Site

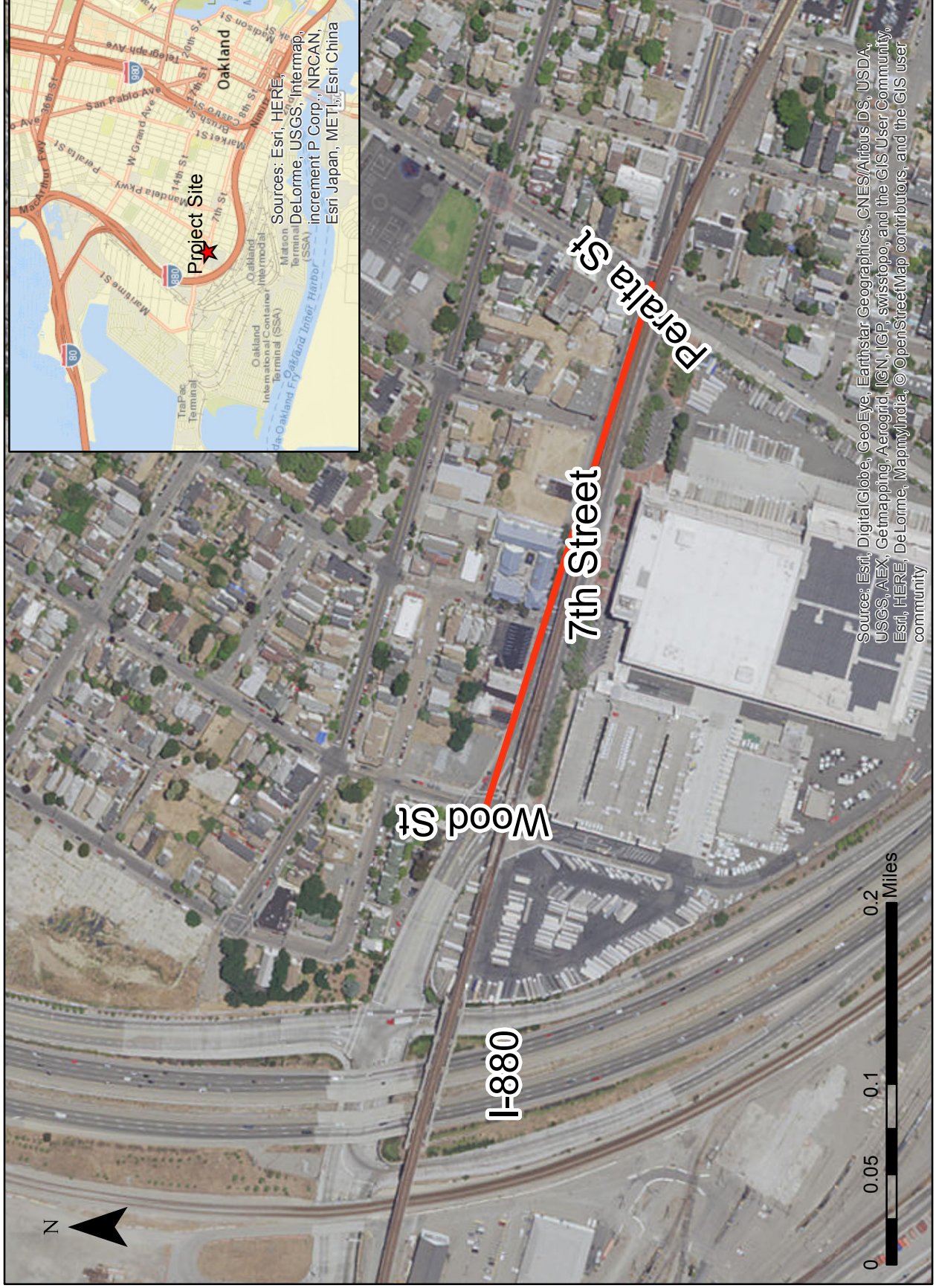

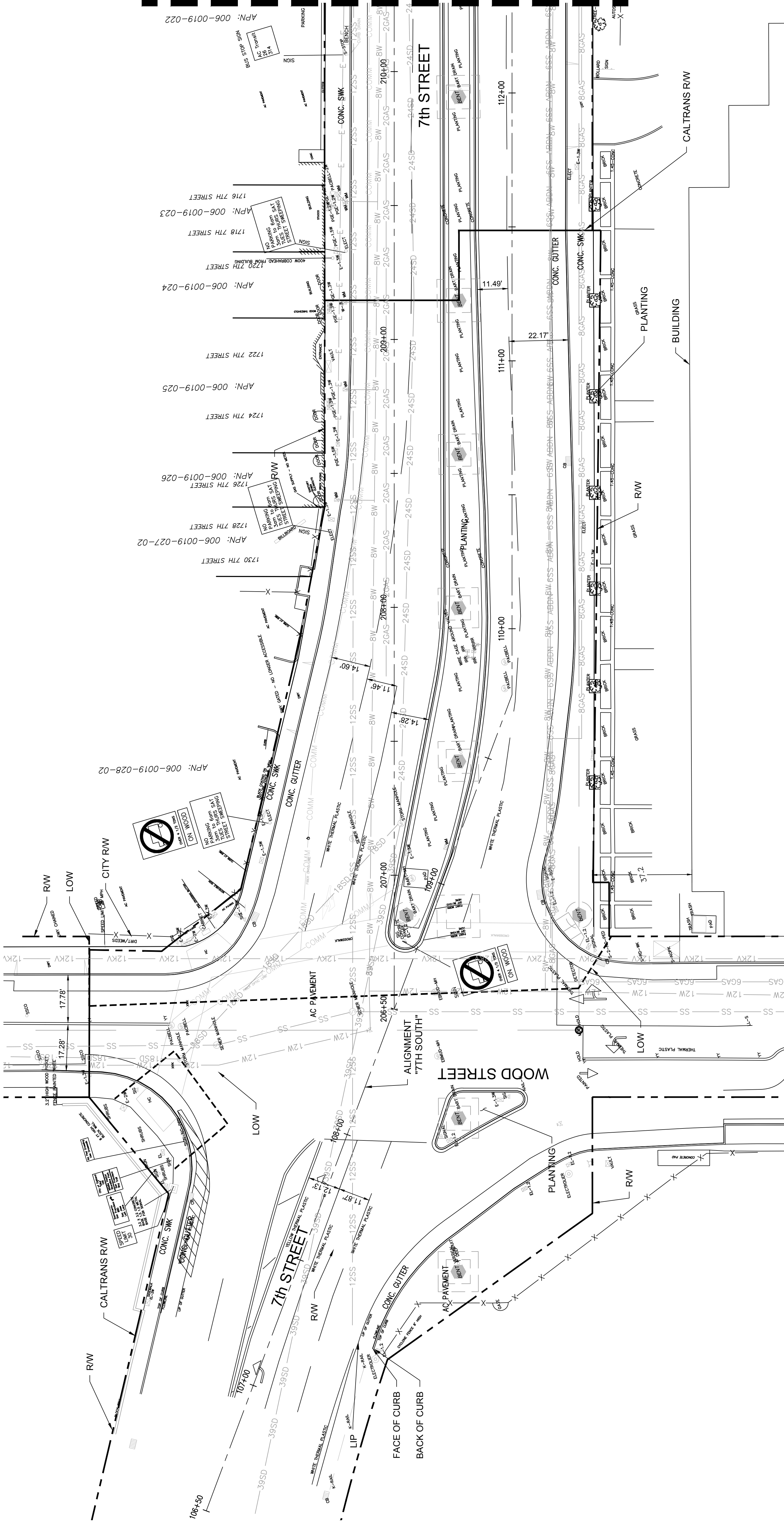

STA 112+35 MATCHLINE
SEE SHEET C-2.3

LEGEND

- UTILITY BOX ABOVE GROUND UTILITY
- SIGN
- ELECTROLIER
- CATCHBASIN
- SEWER MANHOLE
- WATER VALVE
- FIRE HYDRANT
- GENERAL TREE
- PINE TREE
- EUCALYPTUS TREE
- CITY MONUMENT
- SURVEY CONTROL POINT

7TH STREET PLAN A STA 106+50 TO STA 112+35 C-2.2 SCALE: 1" = 20'

- NOTE:**
- FOR MONUMENT AND ALIGNMENT DATA SEE SHEET C-2.1.
 - THE SANITARY AND STORM SEWER LINES SHOWN ON THE CITY MAP DOES NOT REFLECT THE IMPROVEMENTS ALONG 7TH STREET FROM WILLOW STREET TO WOOD STREET.

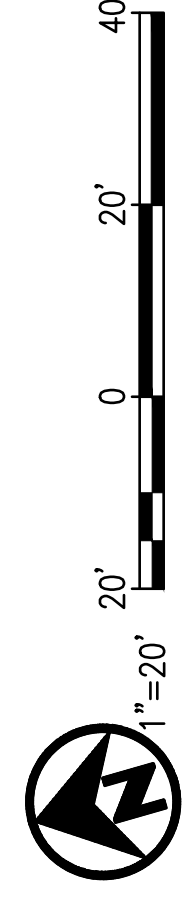

PIS Surveys, Inc.
LAND & HYDROGRAPHIC SURVEYORS
2222 Livingstone Street, Suite 202
Oakland, California 94612
510.261.0600 FAX 510.261.3303
e-mail: pissan@piscell.net

PROJECT NO.		G313170	SHEET NO. C-2.2	OF 4
SCALE: AS SHOWN				
DATE: 07/24/2015				

95% CD NOT FOR CONSTRUCTION

URBAN DESIGN
CONSULTING ENGINEERS
4400 Market Street, Suite 800
Oakland, California 94608
510 868 1085 tel
510 225 1782 fax
www.UrbanDesignCE.com

REFERENCE	DATE	BY
35% CD Submittal	01-10-2014	
65% CD Submittal	10-07-2014	
95% CD Submittal	07-24-2015	

CIVIL	No.	DATE	BY
RCE NO. XXX	EXP. XXXX		
CHECKED BY JL			
DESIGNED BY MLK			
DRAWN BY JA			

7TH STREET WOTV STREETScape
PHASE II
EXISTING CONDITIONS
PLAN STA 106+50 TO STA 112+35

CITY OF OAKLAND
DESIGN AND CONSTRUCTION SERVICES DEPARTMENT
250 FRANK H. OSGOOD PLAZA, SUITE 4314 • OAKLAND, CA 94612
(510) 238-3407 • FAX (510) 238-7227

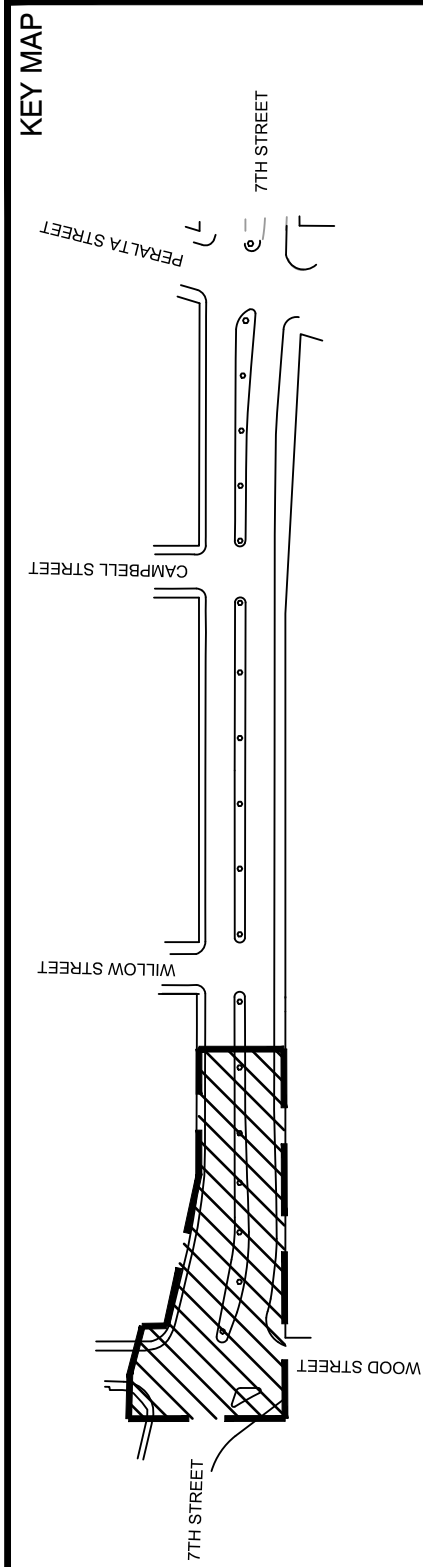

STA 112+35 MATCHLINE, SEE SHEET C-2.2

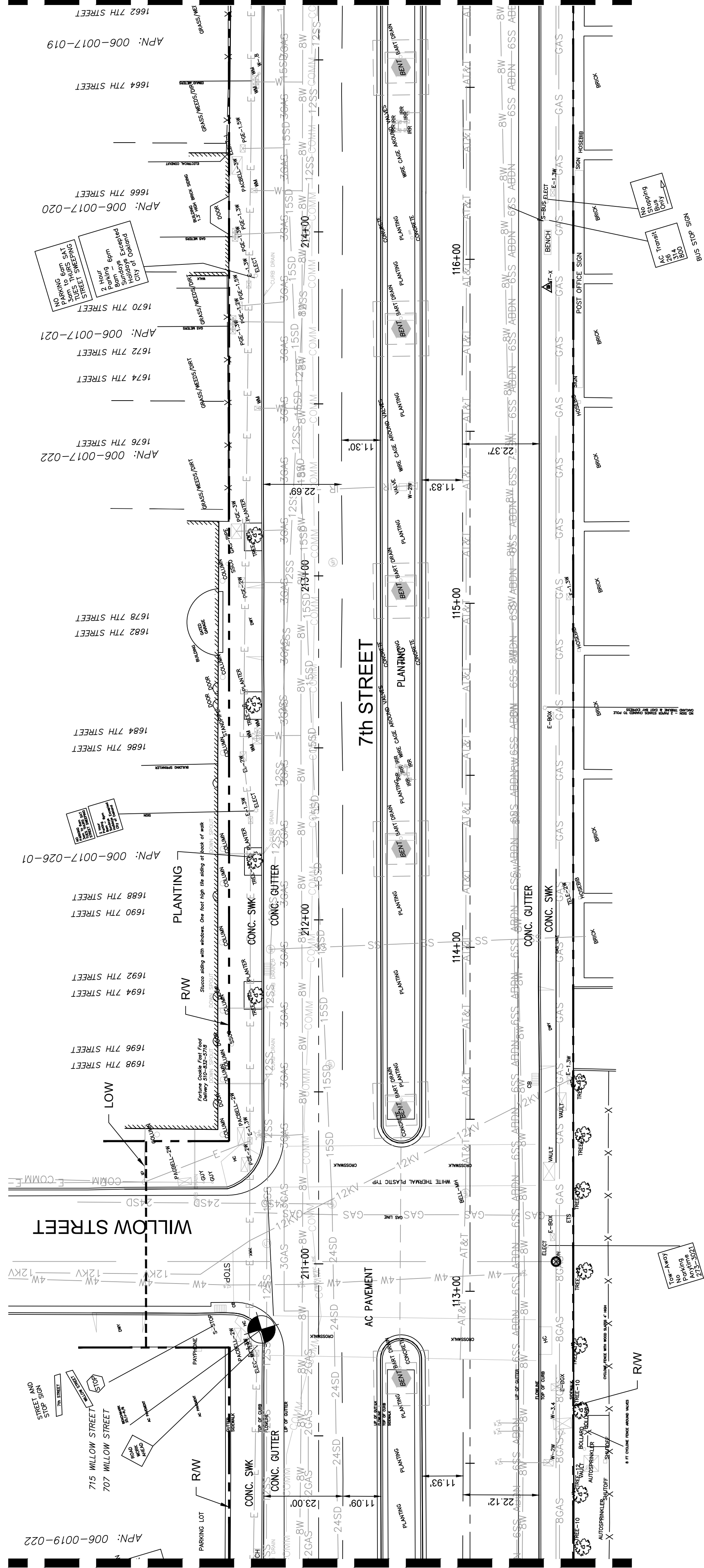

STA 116+70 MATCHLINE, SEE SHEET C-2.4

A 7TH STREET PLAN STA 112+35 TO STA 116+70
C-2.3 SCALE: 1" = 20'

- NOTE:**
1. FOR MONUMENT AND ALIGNMENT DATA SEE SHEET C-2.1.
 2. THE SANITARY AND STORM SEWER LINES SHOWN ON THE CITY MAP DOES NOT REFLECT THE IMPROVEMENTS ALONG 7TH STREET FROM WILLOW STREET TO WOOD STREET.

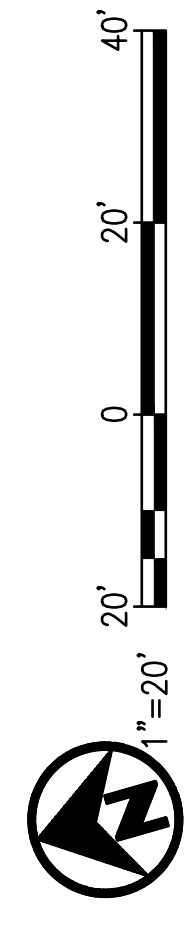

PLS Surveys, Inc.
LAND & HYDROGRAPHIC SURVEYORS
2220 Livingstone Street, Suite 202
Oakland, California 94612
510.261.0600 FAX 510.261.3303
e-mail: pssur@pocbell.net

PROJECT NO.	G313170
SCALE: AS SHOWN	SHEET NO. C-2.3
HOR. VERT.	5 OF 77
DATE: 07/24/2015	

95% CD NOT FOR CONSTRUCTION

URBANDESIGN
CONSULTING ENGINEERS
PROFESSIONAL ENGINEERS (CIVIL) (ELECTRICAL) (MECHANICAL) (PLUMBING)
4400 Market Street, Suite 800
Oakland, California 94608
510 868 1085 tel
510 225 1782 fax
www.UrbanDesignCE.com

REFERENCE	DATE	BY
35% CD Submittal	01-10-2014	
65% CD Submittal	10-07-2014	
95% CD Submittal	07-24-2015	

CIVIL

NO. XXX EXP. XXXX

CHECKED BY JL

DESIGNED BY MLK

DRAWN BY JA

7TH STREET WOTV STREETScape PHASE II

EXISTING CONDITIONS

PLAN STA 112+35 TO STA 116+70

CITY OF OAKLAND
DESIGN AND CONSTRUCTION SERVICES DEPARTMENT
250 FRANK H. OSGOOD PLAZA, SUITE 4314 • OAKLAND, CA 94612
(510) 238-3407 • FAX (510) 238-7227

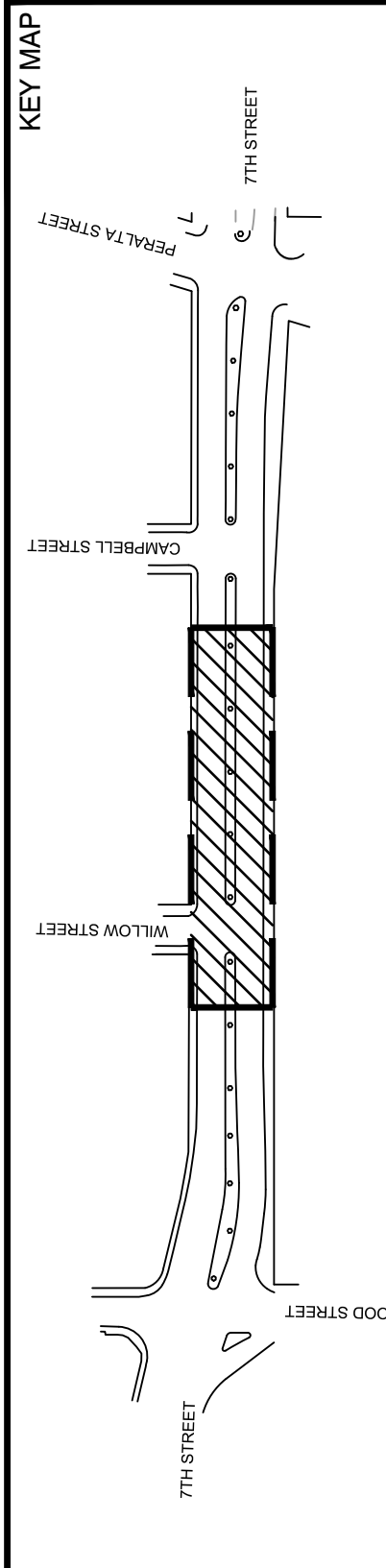

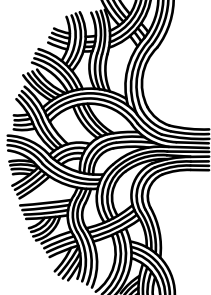

CITY OF OAKLAND
DESIGN AND CONSTRUCTION SERVICES DEPARTMENT
250 FRANK H. OSGOOD PLAZA, SUITE 4314 • OAKLAND, CA 94612
(510) 238-9407 • FAX (510) 238-7227

7TH STREET WOTV STREETScape
PHASE II
EXISTING CONDITIONS
PLAN STA 116+70 TO STA 122+00

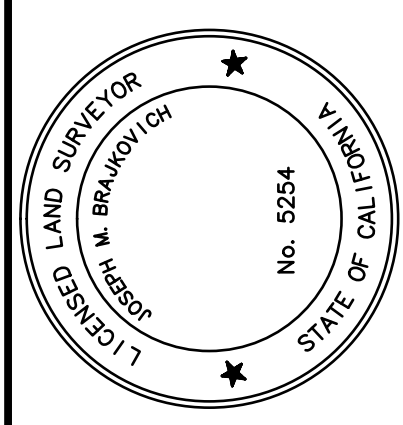

No.	DATE	BY	REFERENCE
	01-10-2014		95% CD Submittal
	10-07-2014		95% CD Submittal
	07-24-2015		95% CD Submittal

URBANDESIGN
CONSULTING ENGINEERS
PROFESSIONAL ENGINEERS (CIVIL) (C) (S) (E) (M) (P) (S) (T) (E) (R) (M) (E) (N) (T) (E) (R)
4400 Market Street, Suite 800
Oakland, California 94608
510 868 1085 tel
510 225 1782 fax
www.UrbanDesignCE.com

PROJECT NO.
G313170
95% CD
NOT FOR
CONSTRUCTION

SCALE: AS SHOWN
HOR. VERT.
C-2.4
6 OF 77
DATE: 07/24/2015
PLS Surveys, Inc.
LAND & HYDROGRAPHIC SURVEYORS
2226 Livingstone Street, Suite 202
Oakland, California 94612
510.261.0900 FAX 510.261.3303
e-mail: plsur@pcbell.net

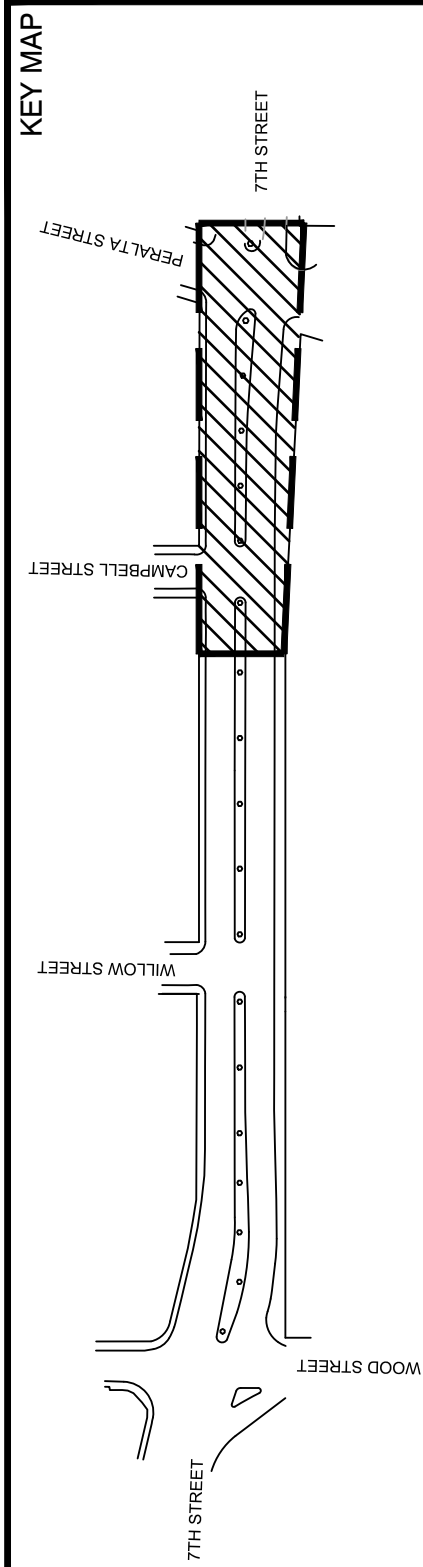

A 7TH STREET PLAN STA 116+70 TO STA 122+00
SCALE: 1" = 20'

NOTE:
1. FOR MONUMENT AND ALIGNMENT DATA SEE SHEET C-2.1.
2. THE SANITARY AND STORM SEWER LINES SHOWN ON THE CITY MAP DOES NOT REFLECT THE IMPROVEMENTS ALONG 7TH STREET FROM WILLOW STREET TO WOOD STREET.

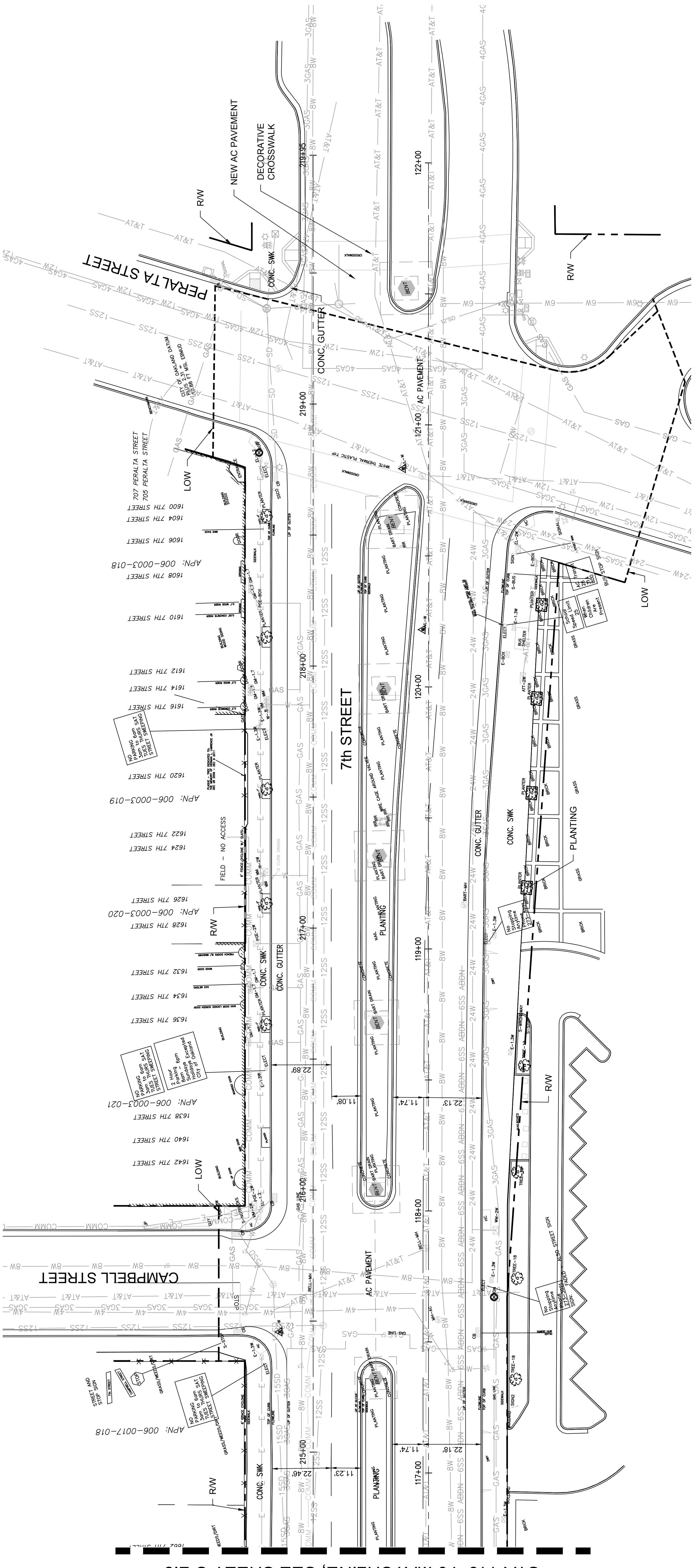

STA 116+70 MATCHLINE, SEE SHEET C-2.3

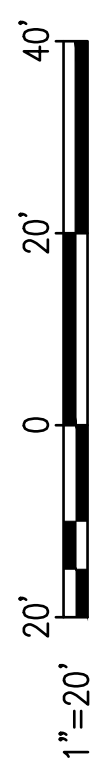

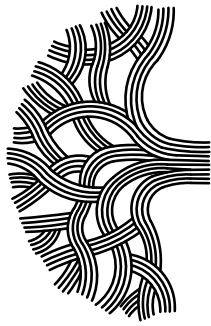

CITY OF OAKLAND
 DESIGN AND CONSTRUCTION SERVICES DEPARTMENT
 250 FRANK H. OSGOOD PLAZA, SUITE 4314 • OAKLAND, CA 94612
 (510) 238-3407 • FAX (510) 238-7227

**7TH STREET WOTV STREETSCAPE
 PHASE II**

TYPICAL SECTIONS

CIVIL	No.	DATE	BY	REFERENCE
		01-10-2014		95% CD Submittal
		10-07-2014		65% CD Submittal
		07-24-2015		95% CD Submittal

PROFESSIONAL ENGINEER	REG. NO.	EXP.	CHECKED BY	DESIGNED BY	DRAWN BY
JOHN J. LING	C60493	6/30/16	JL	MLK	JA

95% CD NOT FOR CONSTRUCTION	PROJECT NO. G313170
-----------------------------	----------------------------

URBANDESIGN
 CONSULTING ENGINEERS
 PROFESSIONAL ENGINEERS IN THE STATE OF CALIFORNIA
 4400 Market Street, Suite 800
 Oakland, California 94608
 510 868 1085 tel
 510 225 1782 fax
 www.UrbanDesignCE.com

SCALE: AS SHOWN
 HOR. **C-4.1**
 VERT. **13**
 SHEET NO. **C-4.1**
 OF **77**
 DATE: 07/24/2015

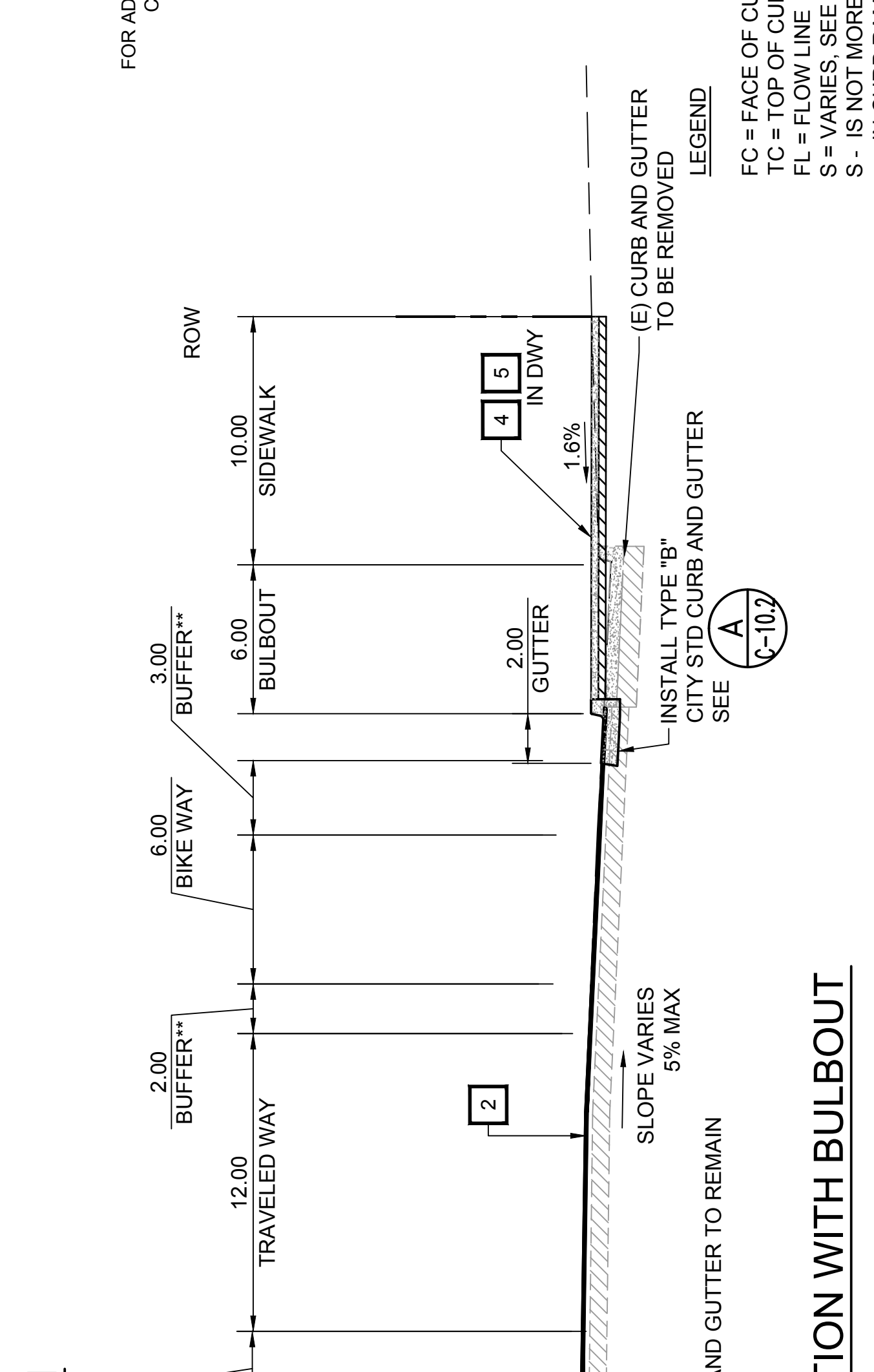
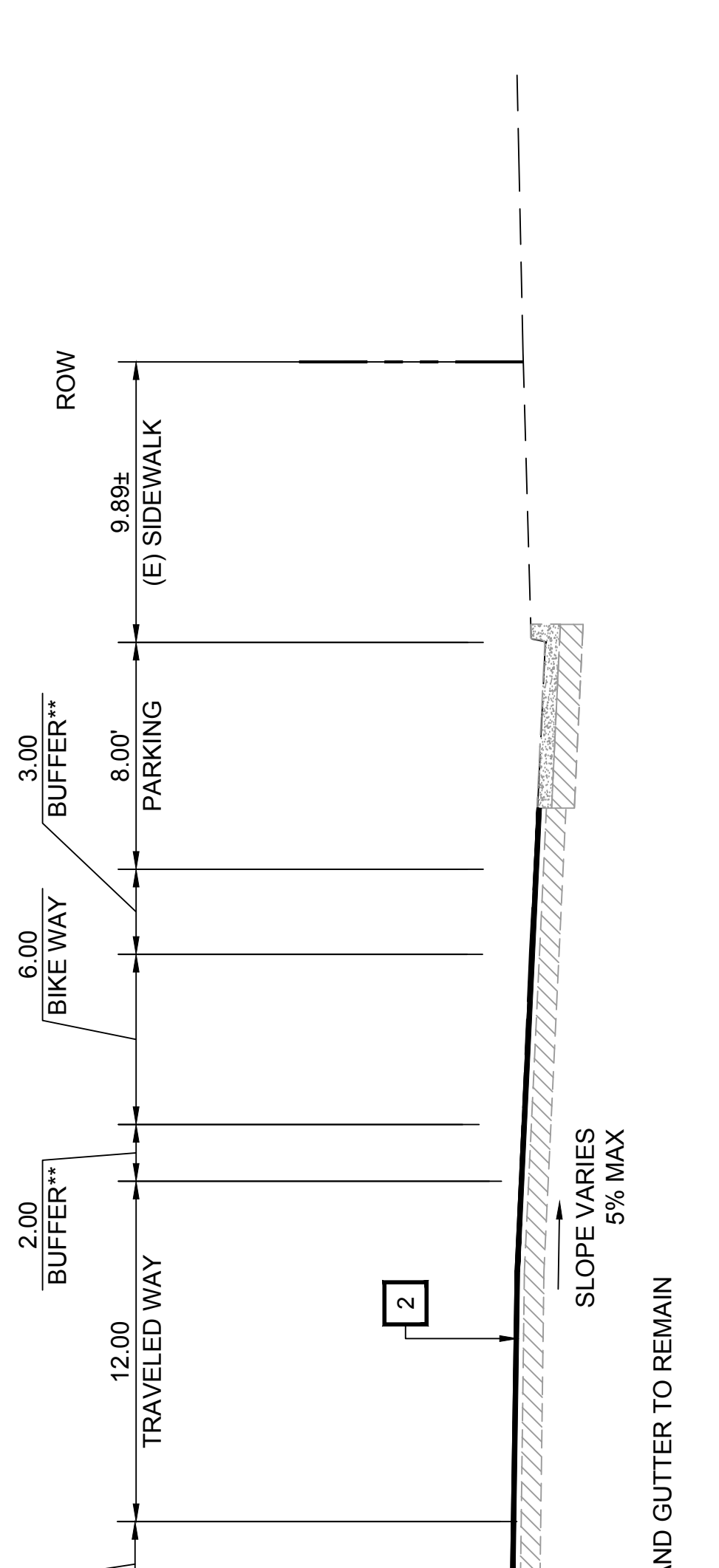
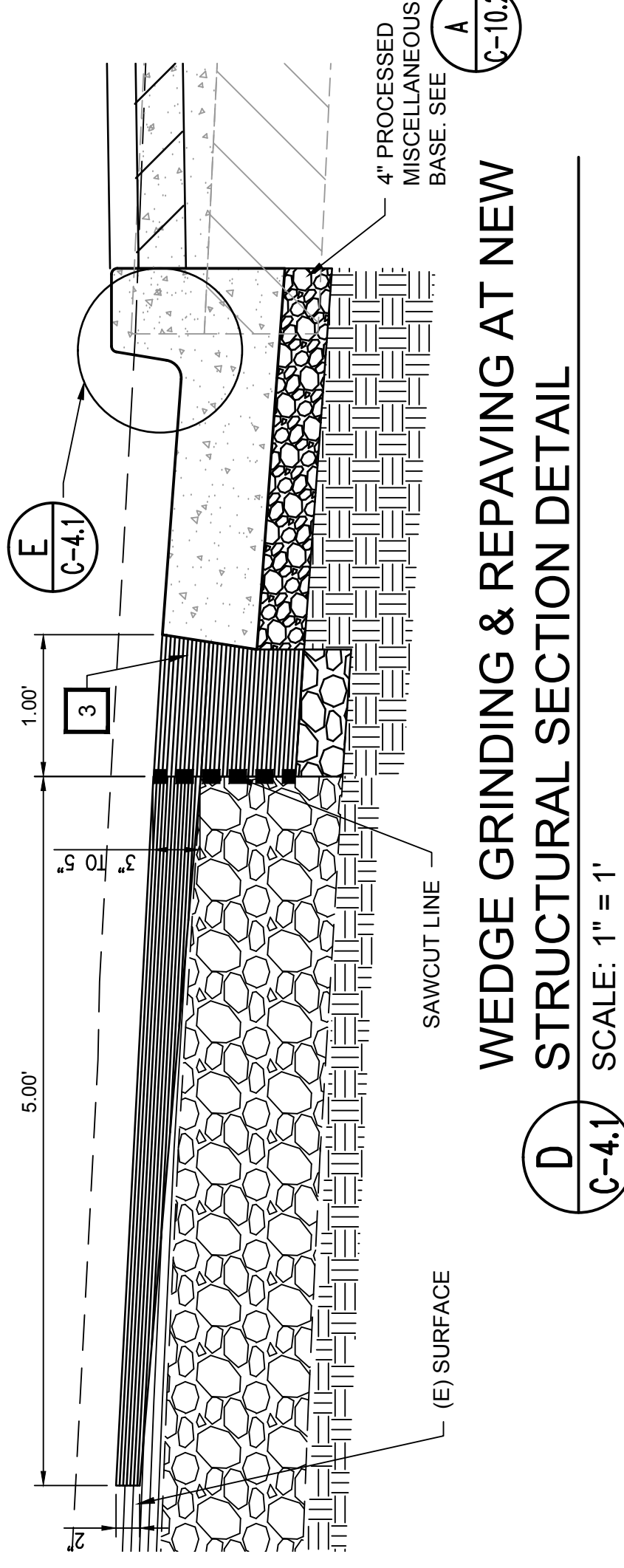
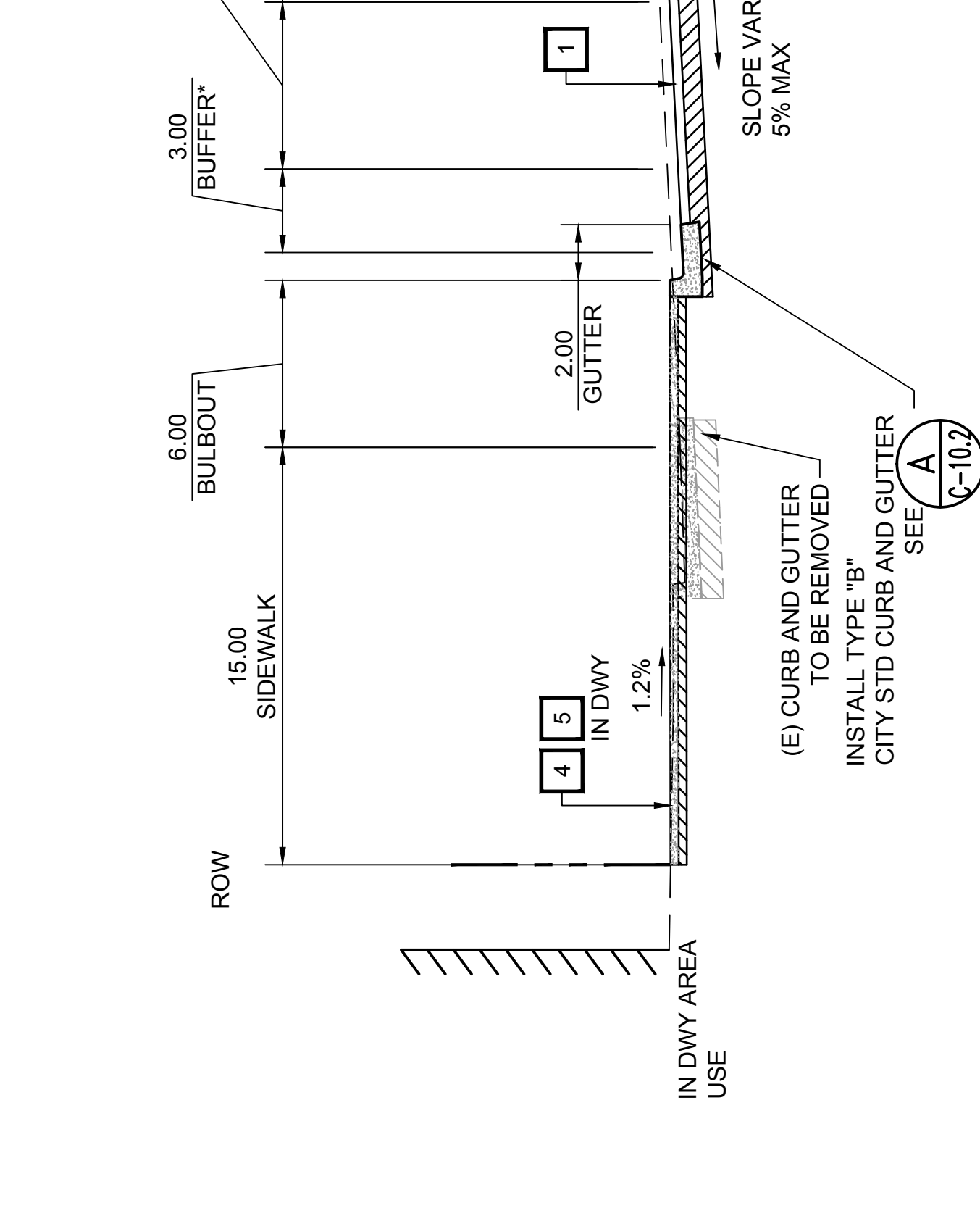
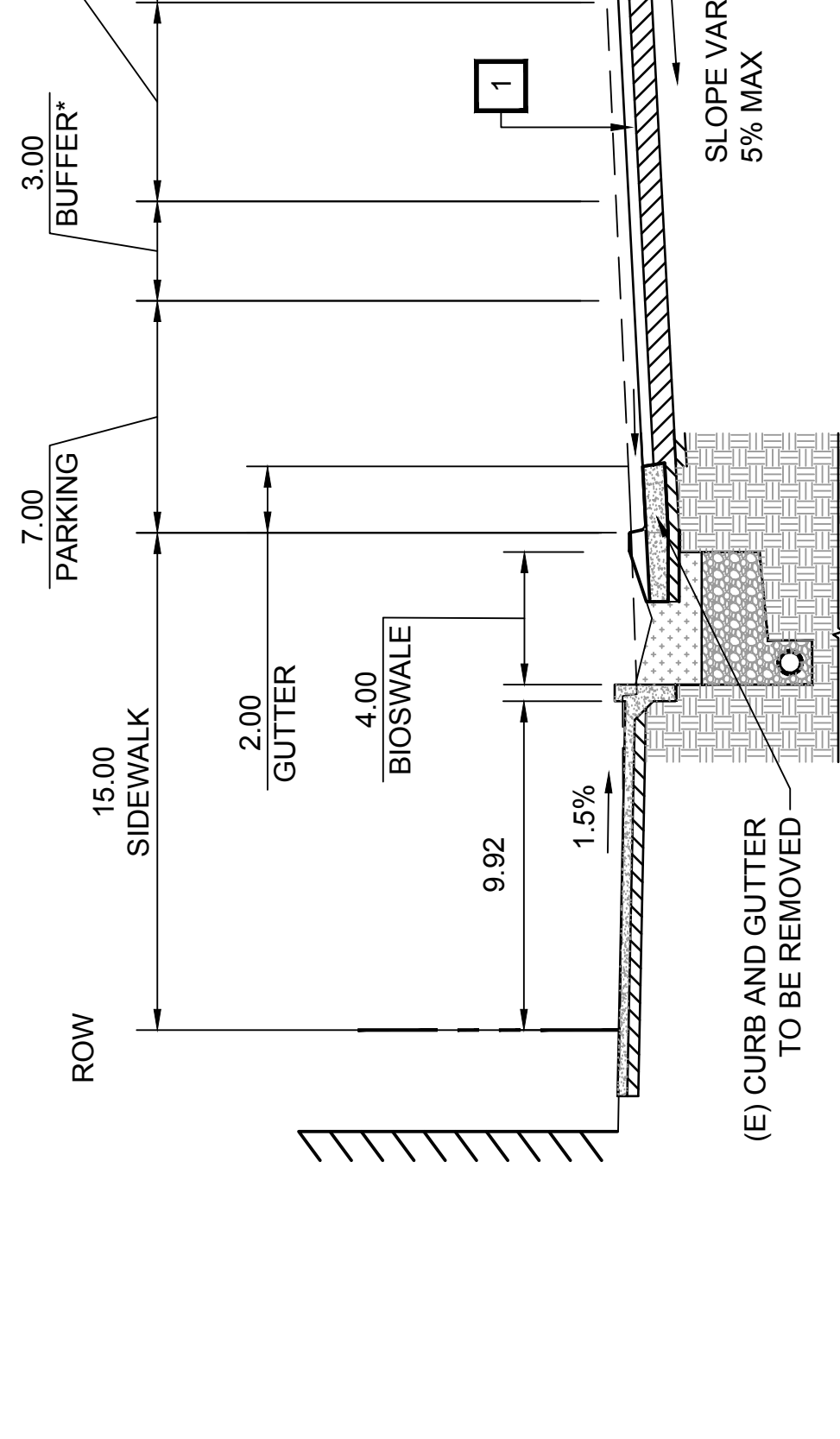
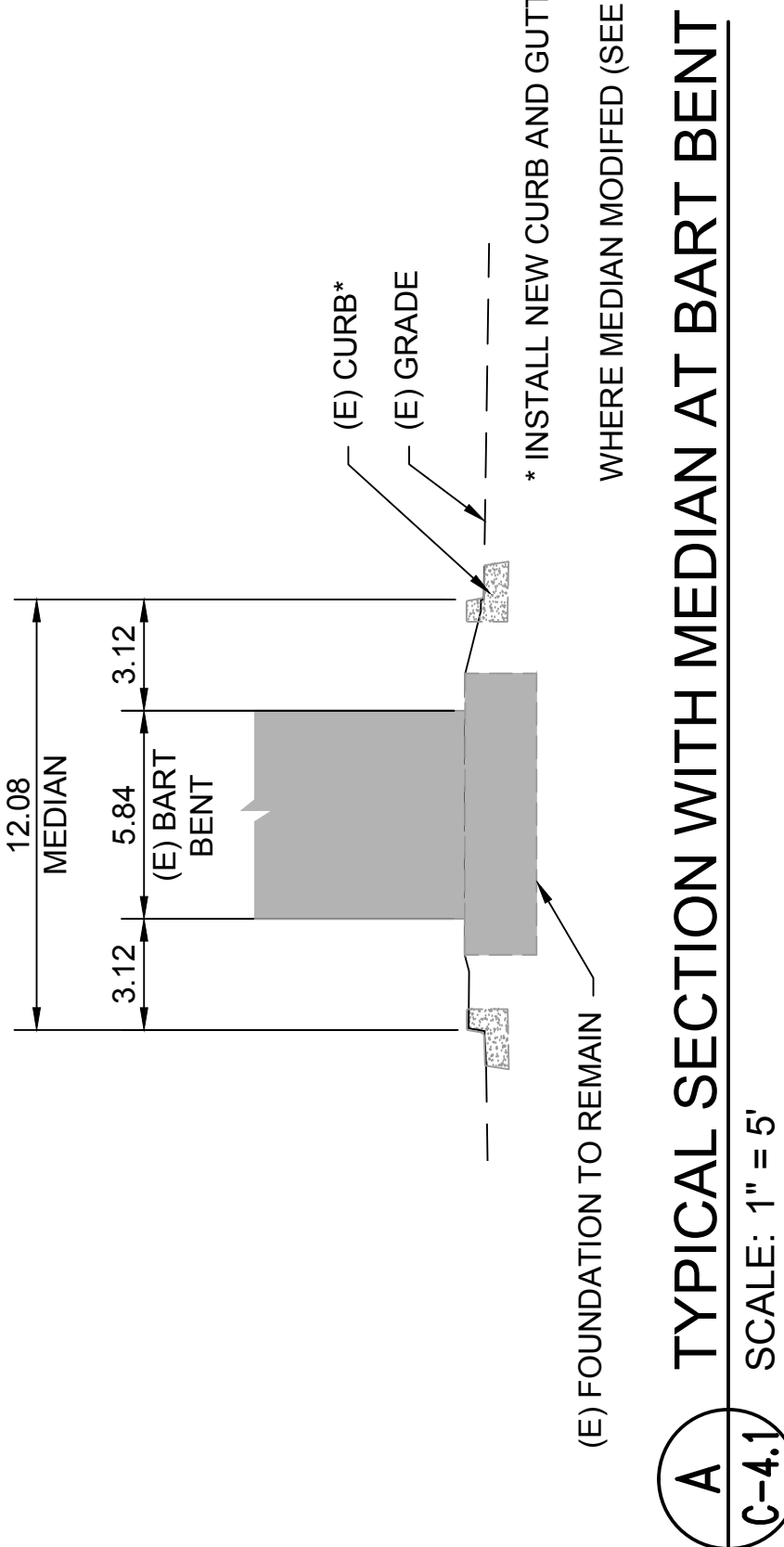

PAVEMENT TYPE LEGEND:

STREET PAVEMENT

- 1 4" AC - PAVEMENT
8" AGGREGATE BASE CLASS 2 OVER
6" COMPACTED SUBGRADE PER CITY
STANDARD
- 2 2" GRIND AND 2" AC OVERLAY ON
EXISTING GRADE
- 3 12" AC PLUG OVER 4" CLASS 2
AGGREGATE BASE OVER COMPACTED
SUBGRADE PER CITY STANDARD

SIDEWALK PAVEMENT

- 4 3.5" CONCRETE
4.0" AGGREGATE BASE
SEE SHEETS C-6.1, C-6.2, C-6.3
- 5 DRIVEWAY
6" PORTLAND CEMENT CONCRETE
4" AGGREGATE BASE

NOTES:

1. SEE SHEET C-1.0 FOR GENERAL NOTES.

FOR ADDITIONAL CITY STD "TYPE A"
 CURB & GUTTER DIMENSIONS
 SEE **(A) C-10.2**

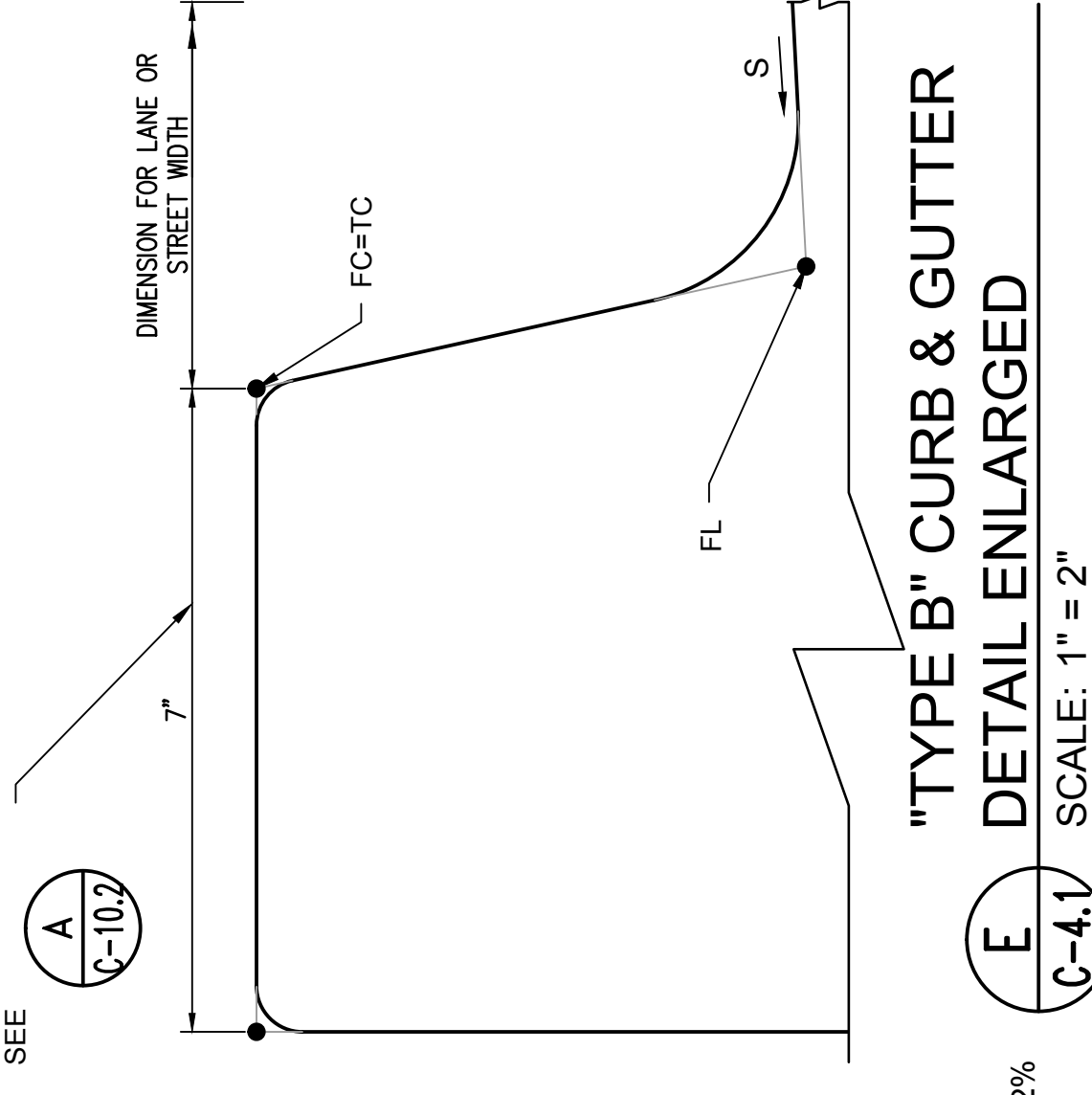

FC = FACE OF CURB
 TC = TOP OF CURB
 FL = FLOW LINE
 S = VARIES. SEE PLAN
 IN CURB RAMP AREA

(E) C-4.1
 SCALE: 1" = 2"

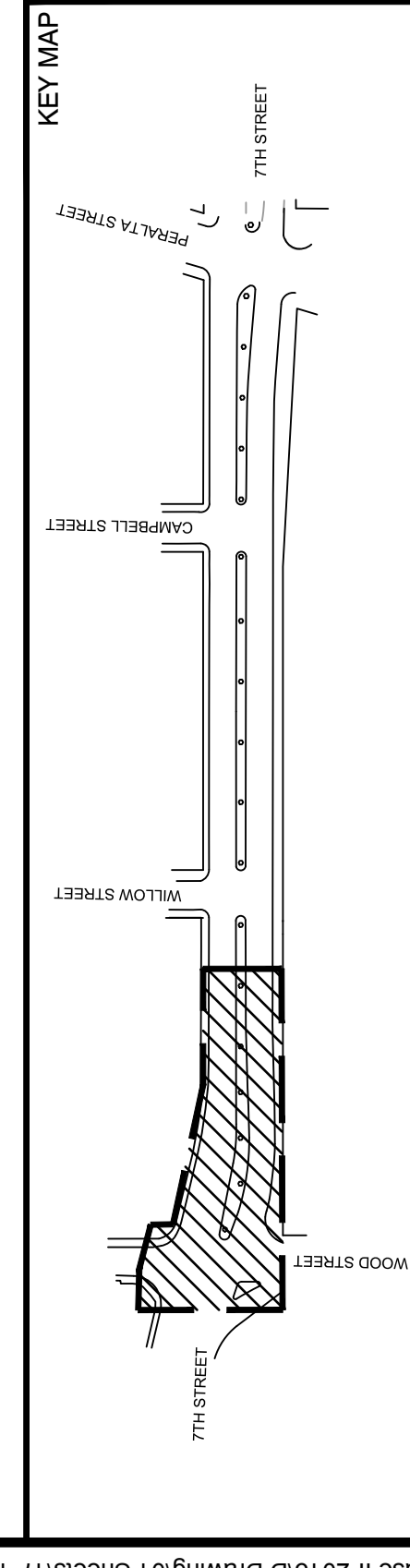
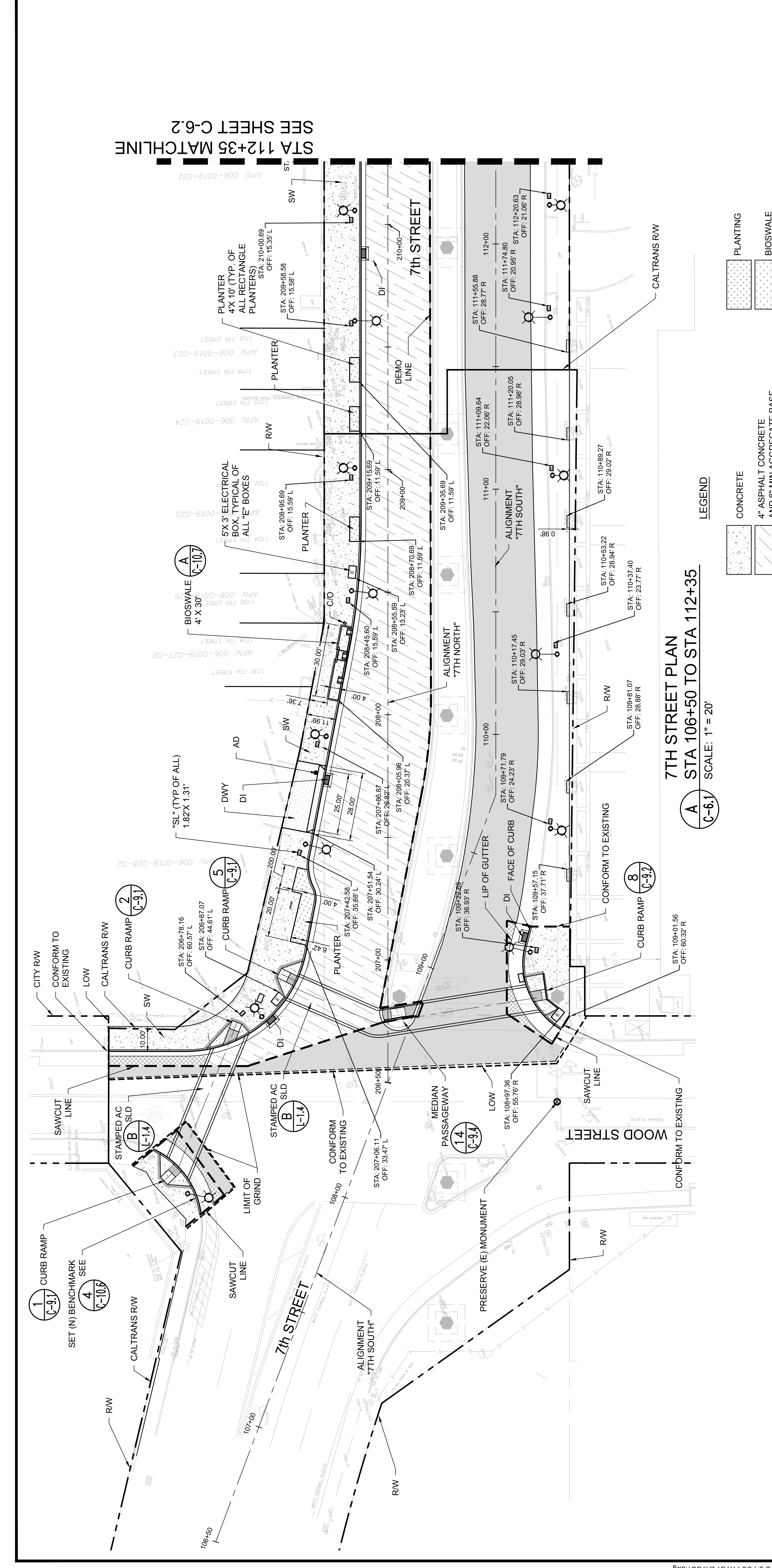

7TH STREET PLAN
A STA 106+50 TO STA 112+35
 SCALE: 1" = 20'

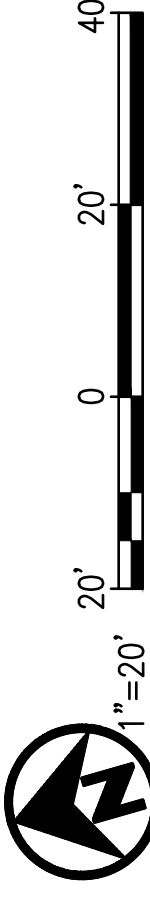
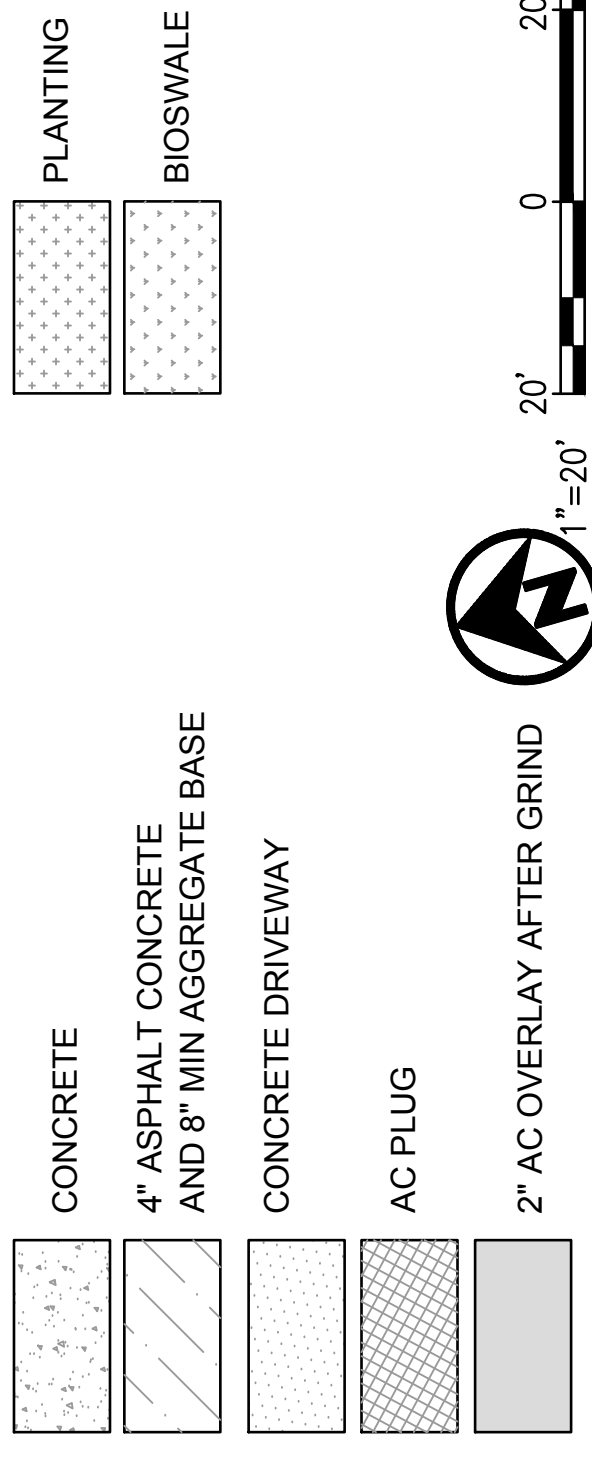

STA 112+35 MATCHLINE
 SEE SHEET C-6.2

<p>CITY OF OAKLAND DESIGN AND CONSTRUCTION SERVICES DEPARTMENT 250 FRANK H. OSGOOD PLAZA, SUITE 4314 • OAKLAND, CA 94612 (510) 238-3407 • FAX (510) 238-7227</p>	<p>7TH STREET WOTV STREETSCAPE PHASE II LAYOUT PLAN STA 106+50 TO STA 112+35</p>			<p>CIVIL</p> <table border="1"> <tr> <th>No.</th> <th>DATE</th> <th>BY</th> <th>REFERENCE</th> </tr> <tr> <td></td> <td>01-10-2014</td> <td></td> <td>95% CD Submittal</td> </tr> <tr> <td></td> <td>10-07-2014</td> <td></td> <td>65% CD Submittal</td> </tr> <tr> <td></td> <td>07-24-2015</td> <td></td> <td>95% CD Submittal</td> </tr> </table>			No.	DATE	BY	REFERENCE		01-10-2014		95% CD Submittal		10-07-2014		65% CD Submittal		07-24-2015		95% CD Submittal
	No.	DATE		BY	REFERENCE																	
	01-10-2014		95% CD Submittal																			
	10-07-2014		65% CD Submittal																			
	07-24-2015		95% CD Submittal																			
<p>7TH STREET WOTV STREETSCAPE PHASE II LAYOUT PLAN STA 106+50 TO STA 112+35</p>		<p>CHECKED BY: JL DESIGNED BY: MLK DRAWN BY: JA</p>																				
<p>CITY OF OAKLAND DESIGN AND CONSTRUCTION SERVICES DEPARTMENT 250 FRANK H. OSGOOD PLAZA, SUITE 4314 • OAKLAND, CA 94612 (510) 238-3407 • FAX (510) 238-7227</p>		<p>URBANDESIGN CONSULTING ENGINEERS 4400 Market Street, Suite 800 Oakland, California 94608 510 868 1085 tel 510 225 1782 fax www.UrbanDesignCE.com</p>		<p>PROJECT NO. G313170</p>																		
		<p>95% CD NOT FOR CONSTRUCTION</p>		<p>SCALE: AS SHOWN HOR: C-6.1 VERT: 17 DATE: 07/24/2015</p>																		

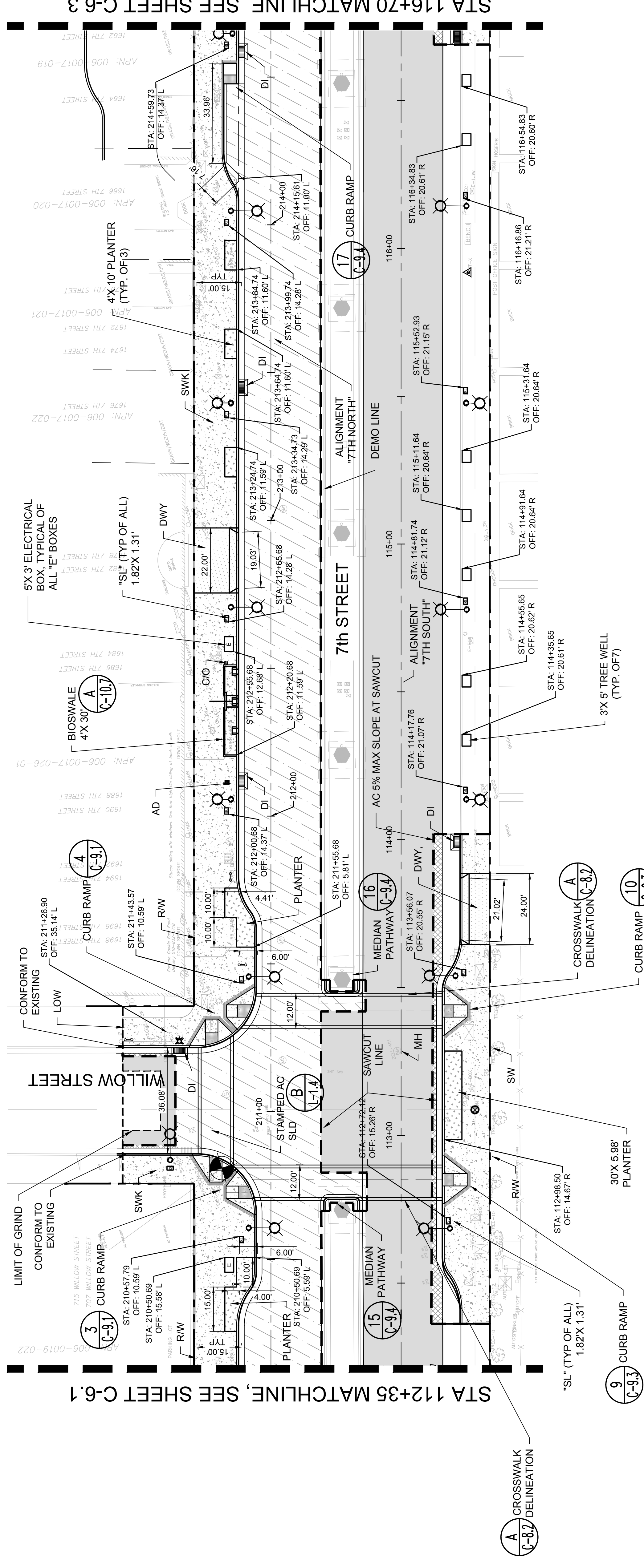

A 7TH STREET PLAN STA 112+35 TO STA 116+70
SCALE: 1" = 20'

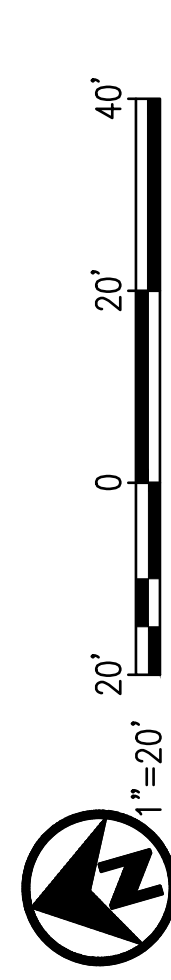
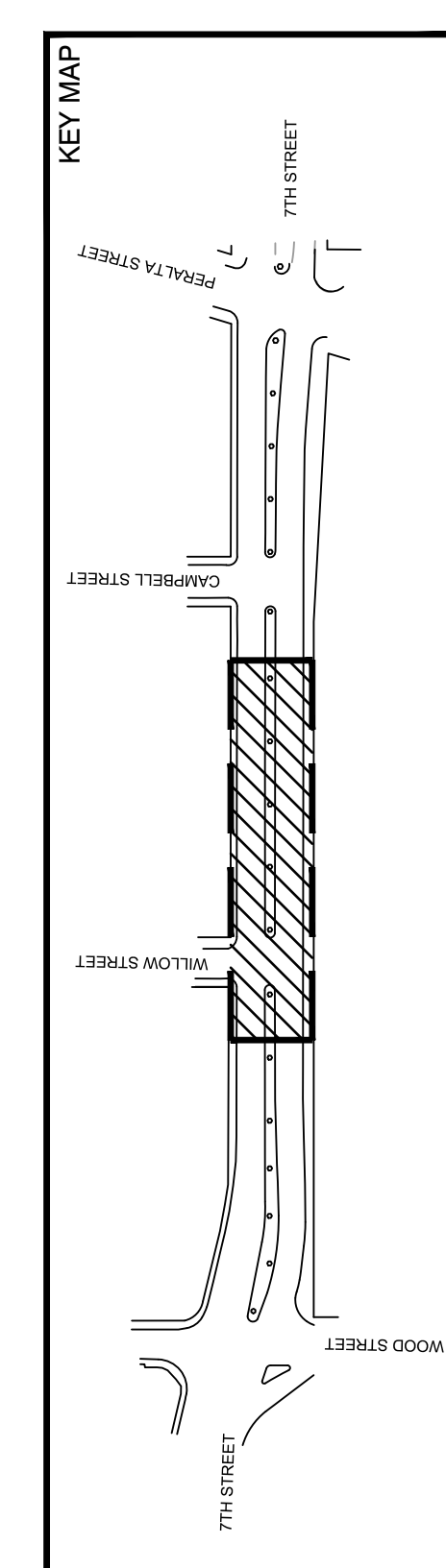
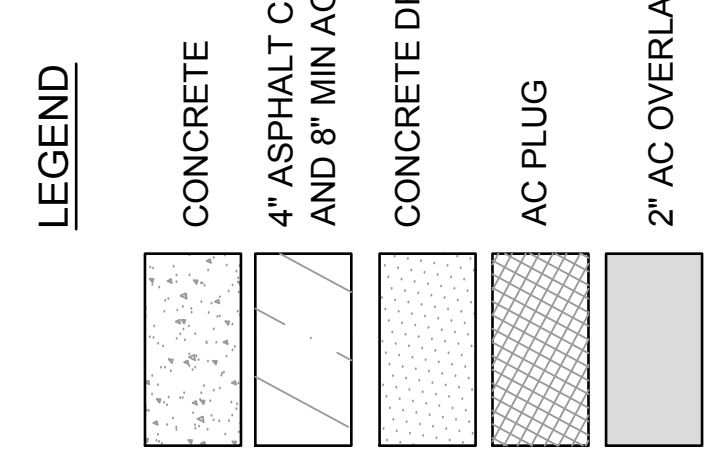

CITY OF OAKLAND
DESIGN AND CONSTRUCTION SERVICES DEPARTMENT
250 FRANK H. OSGOOD PLAZA, SUITE 4314 • OAKLAND, CA 94612
(510) 238-3407 • FAX (510) 238-7227

7TH STREET WOTV STREETSCAPE
PHASE II
LAYOUT PLAN
PLAN STA 112+35 TO STA 116+70

CIVIL	No.	DATE	BY	REFERENCE
		01-10-2014		35% CD Submittal
		10-07-2014		65% CD Submittal
		07-24-2015		95% CD Submittal

PROFESSIONAL ENGINEER	ROE NO. XXX	EXP. XXXX
REGISTERED	C60493	
STATE OF CALIFORNIA	EXP. 6/30/16	
CIVIL ENGINEER	CHECKED BY JL	
DESIGNED BY MLK		
DRAWN BY JA		

95% CD NOT FOR CONSTRUCTION	PROJECT NO. G313170
-----------------------------------	-------------------------------

SCALE: AS SHOWN	SHEET NO. C-6.2
DATE: 07/24/2015	18 OF 77

URBANDESIGN CONSULTING ENGINEERS
4400 Market Street, Suite 800
Oakland, California 94608
510 868 1085 tel
510 225 1782 fax
www.UrbanDesignCE.com

U:\Projects\120127 7th Street Phase II\2013D Drawing\01 Sheets\17-19 C-6-1-6-3 7TH ST LAYOUT.dwg
PLOT DATE: 08-19-15
PLOTTED BY: Michael

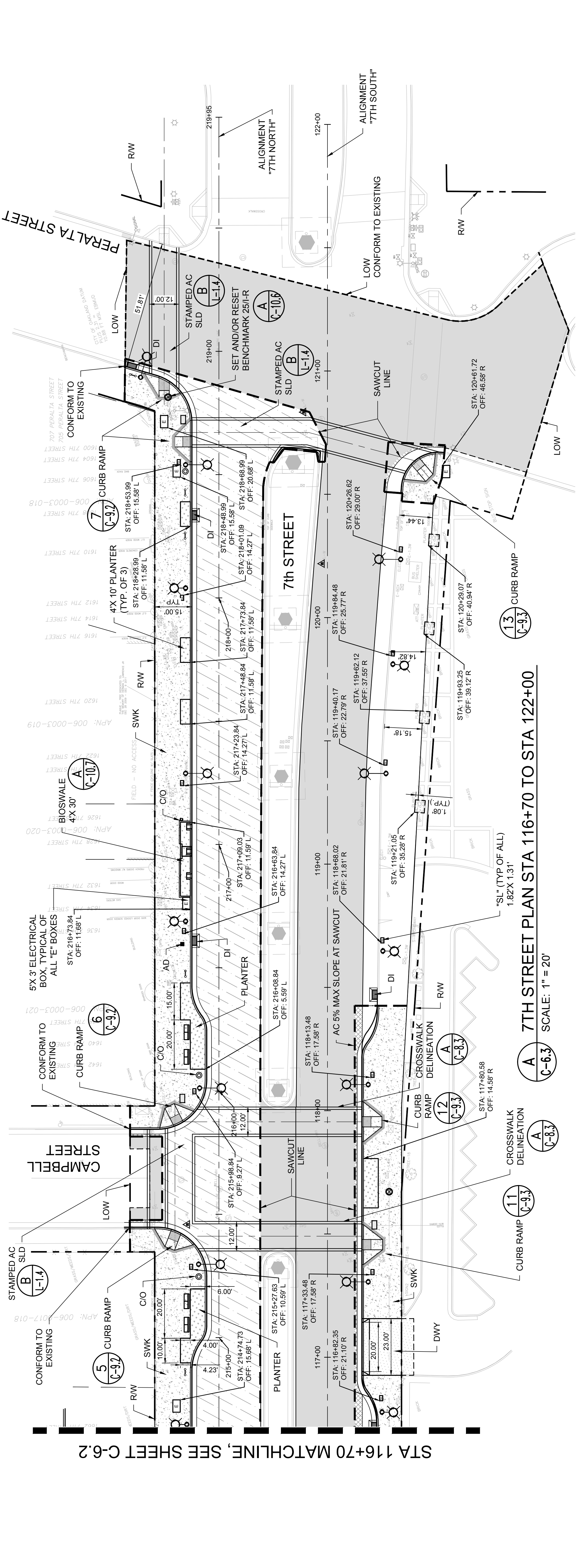

STA 116+70 MATCHLINE, SEE SHEET C-6.2

7TH STREET PLAN STA 116+70 TO STA 122+00

SCALE: 1" = 20'

LEGEND

- CONCRETE
- 4" ASPHALT CONCRETE AND 8" MIN AGGREGATE BASE
- CONCRETE DRIVEWAY
- AC PLUG
- 2" AC OVERLAY AFTER GRIND
- PLANTING
- BIOSWALE

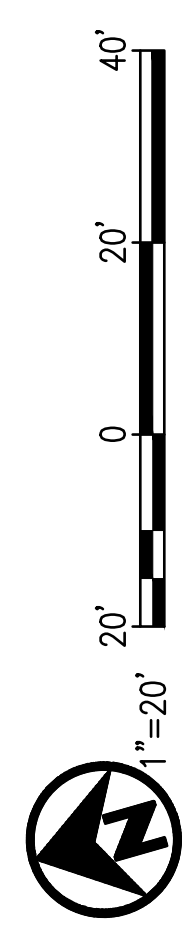
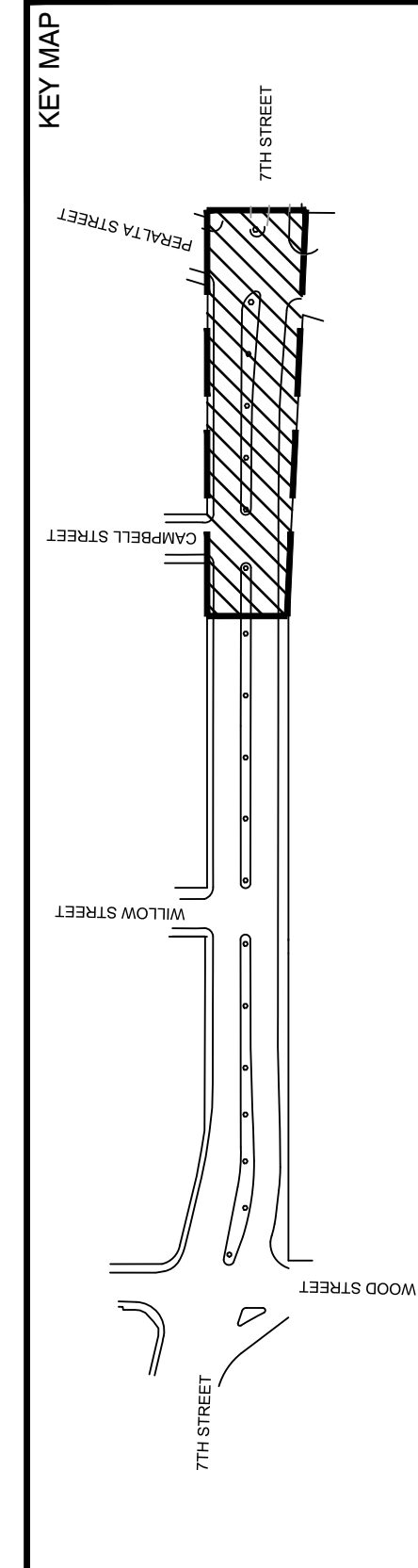

PROJECT NO.
G313170

95% CD
NOT FOR CONSTRUCTION

URBANDESIGN
CONSULTING ENGINEERS
4400 Market Street, Suite 800
Oakland, California 94608
510 868 1085 tel
510 225 1782 fax
www.UrbanDesignCE.com

REFERENCE	DATE	BY
95% CD Submittal	01-10-2014	
95% CD Submittal	10-07-2014	
95% CD Submittal	07-24-2015	

No.	DATE	BY
	01-10-2014	
	10-07-2014	
	07-24-2015	

7TH STREET WOTV STREETSCAPE PHASE II
LAYOUT PLAN
PLAN STA 116+70 TO STA 122+00

CITY OF OAKLAND
DESIGN AND CONSTRUCTION SERVICES DEPARTMENT
250 FRANK H. OSGOOD PLAZA, SUITE 4314 • OAKLAND, CA 94612
(510) 238-3407 • FAX (510) 238-7227

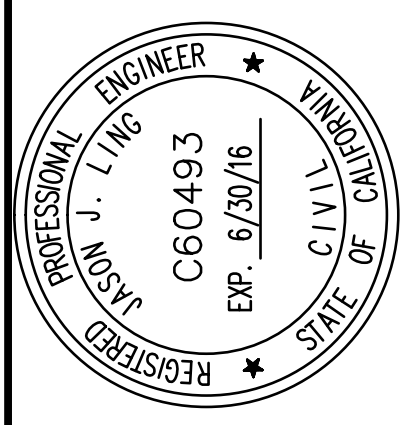

DRAWING NAME: U:\Projects\120127 7th Street Phase II\2013D Drawing\01 Sheets\17-19 C-6-1-3 7TH ST LAYOUT.dwg
PLOT DATE: 08-19-15
PLOTTED BY: Michael

SHEET NO. **C-6.3**
OF 19

SCALE: AS SHOWN
HOR. VERT. DATE: 07/24/2015

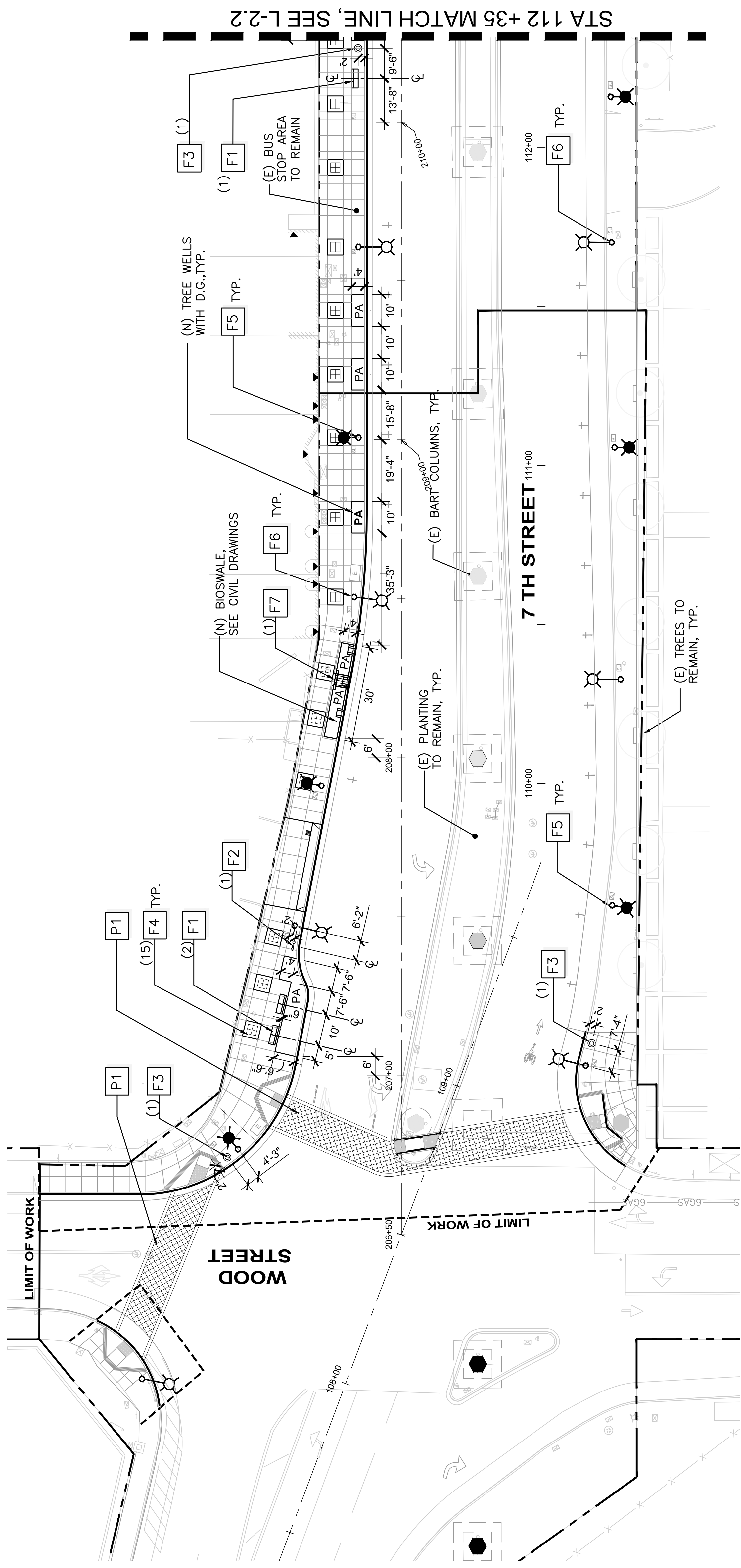

A LANDSCAPE PLAN STA 107+00 TO STA 112+35
SCALE: 1" = 20'

LAYOUT LEGEND

SYMBOL	KEY	DESCRIPTION	DETAIL
	P1	STAMPED ASPHALT PAVING AT CROSSWALK	SEE DETAIL B, SHEET L-2.4
	P2	NEW CROSSWALK	SEE CIVIL DWGS
	F1	BENCH	SEE DETAIL C, SHEET L-2.4
	F2	BIKE RACK	SEE DETAIL D, SHEET L-2.4
	F3	TRASH RECEPTACLE	SEE DETAIL A, SHEET L-2.5
	F4	WALK OF FAME PLAQUE	SEE DETAIL A, SHEET L-2.4

SYMBOL	KEY	DESCRIPTION	DETAIL
	F5	NEW PEDESTRIAN LIGHT	SEE ELECTRICAL DWGS
	F6	NEW STREET LIGHT	SEE ELECTRICAL DWGS
	F7	METAL GRATE	SEE DETAIL B, SHEET L-2.5

ABBREVIATION

- (E) EXISTING
- (N) NEW
- PA PLANTING AREA
- TYP. TYPICAL
- D.G. DECOMPOSED GRANITE

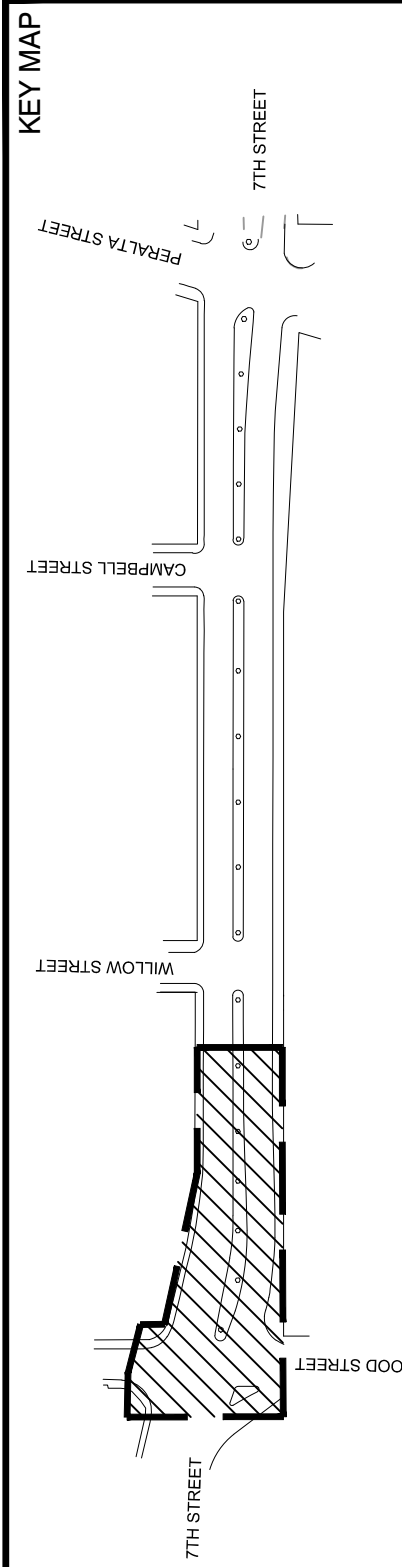

CITY OF OAKLAND
DESIGN AND CONSTRUCTION SERVICES DEPARTMENT
250 FRANK H. OGAWA PLAZA, SUITE 4014 • OAKLAND, CA 94612
(510) 236-5437 • FAX (510) 236-7227

7TH STREET WOTV STREETSCAPE PHASE II

LAYOUT PLAN

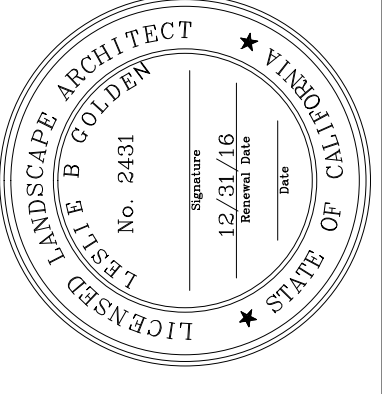

No.	DATE	BY	REFERENCE
	01-10-2014		35% CD Submittal
	10-06-2014		65% CD Submittal
	07-24-2015		95% CD Submittal

GOLDEN ASSOCIATES
LANDSCAPE ARCHITECTURE
URBAN DESIGN & PLANNING
300 FRANK H. OGAWA PLAZA, SUITE 308
OAKLAND, CA 94612
T: 510.465.4030
F: 510.465.5325
CA LIC. #8431

95% CD NOT FOR CONSTRUCTION

PROJECT NO. **G313170**

SCALE: AS SHOWN
HOR. VERT.
SHEET NO. **L-2.1**
DATE: 07/24/2015
OF **77**

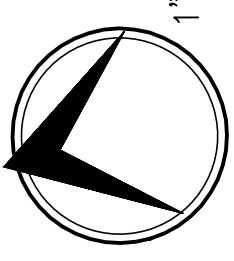

LAYOUT NOTE

1. CONTRACTOR SHALL VERIFY ALL GRADES, EXISTING CONDITIONS AND DIMENSIONS IN THE FIELD PRIOR TO COMMENCING WORK. ALL DISCREPANCIES OR QUESTIONS SHALL BE BROUGHT TO THE ATTENTION OF THE LANDSCAPE ARCHITECT FOR RESOLUTION.
2. ALL WRITTEN DIMENSIONS SUPERSEDE ALL SCALED DISTANCES AND DIMENSIONS. ALL DIMENSIONS ARE TO BACK OF CURB AND CENTERLINE UNLESS OTHERWISE NOTED ON DRAWINGS.
3. ALL CURVES AND TRANSITIONS BETWEEN CURVES AND STRAIGHT EDGES SHALL BE SMOOTH.
4. SEE IRRIGATION PLANS FOR LOCATION OF IRRIGATION PIPING. SLEEVES SHALL ACCOMMODATE SHALL BE IN PLACE UNDER AND THROUGH SLABS AND WALLS PRIOR TO POURING.
5. SCORELINES IN SIDEWALKS SHALL BE EQUALLY SPACED, NOT TO EXCEED THE WIDTH OF THE WALKWAYS, UNLESS OTHERWISE SHOWN. EXPANSION JOINTS IN SIDEWALKS SHALL BE 30' ON CENTER MAXIMUM.
6. LIGHTING LOCATION SHOWN FOR REFERENCE PURPOSES ONLY. REFER TO ELECTRICAL PLANS FOR ALL LIGHTING INFORMATION.
7. ALL NEW VAULTS AND PULL BOXES ALIGN TO CURB AT MIDDLE OF VAULT 6" OFF SET FROM BACK, UNLESS OTHERWISE NOTED.
8. ALL ANGLES ARE 45 DEGREES, 90 DEGREES OR 135 DEGREES UNLESS OTHERWISE NOTED.

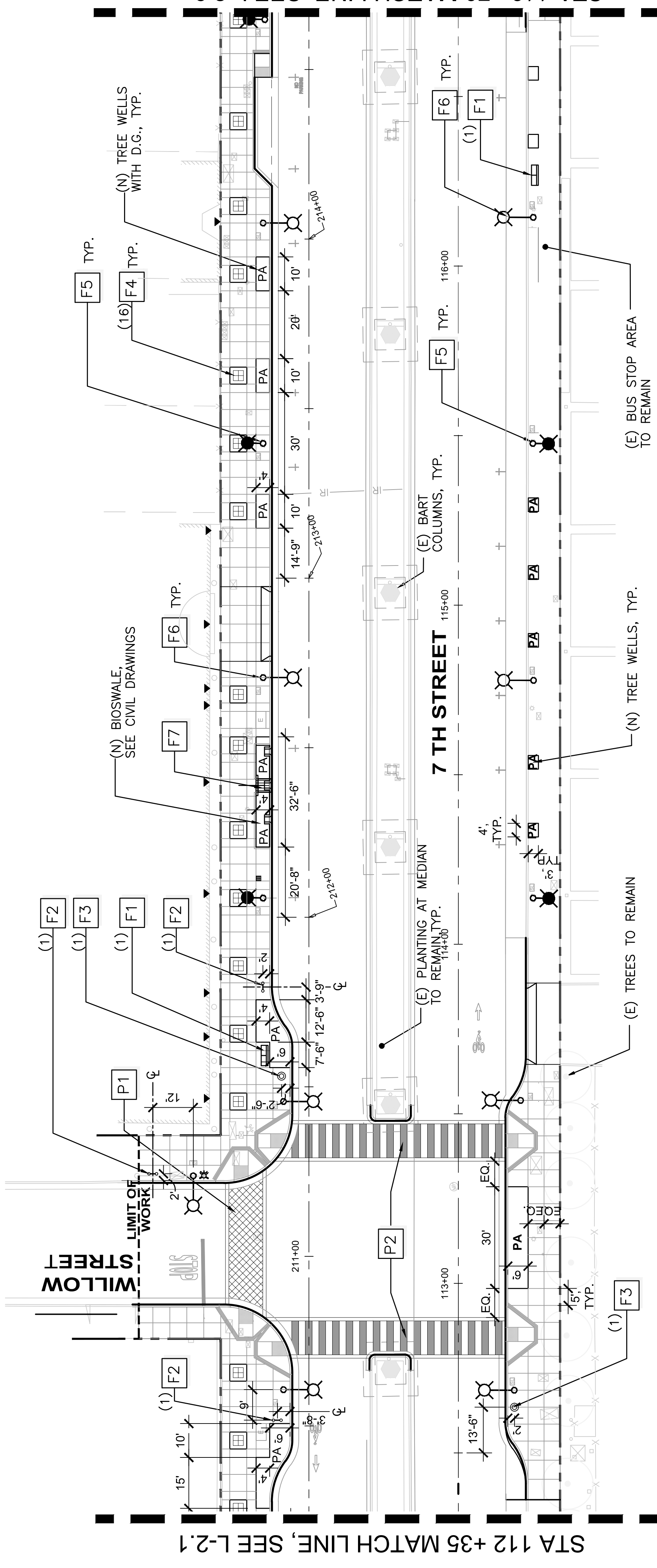

STA 112 +35 MATCH LINE, SEE L-2.1

STA 116 +70 MATCH LINE, SEE L-2.3

A LANDSCAPE PLAN STA 112+35 TO STA 116+70

SCALE: 1" = 20'

LAYOUT LEGEND

SYMBOL	KEY	DESCRIPTION	DETAIL
[Pattern]	P1	STAMPED ASPHALT PAVING AT CROSSWALK	SEE DETAIL B, SHEET L-2.4
[Pattern]	P2	NEW CROSSWALK	SEE CIVIL DWGS
[Symbol]	F1	BENCH	SEE DETAIL C, SHEET L-2.4
[Symbol]	F2	BIKE RACK	SEE DETAIL D, SHEET L-2.4
[Symbol]	F3	TRASH RECEPTACLE	SEE DETAIL A, SHEET L-2.5
[Symbol]	F4	WALK OF FAME PLAQUE	SEE DETAIL A, SHEET L-2.4

ABBREVIATION

- (E) EXISTING
- (N) NEW
- PA PLANTING AREA
- TYP. TYPICAL
- D.G. DECOMPOSED GR

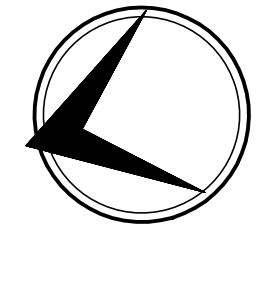
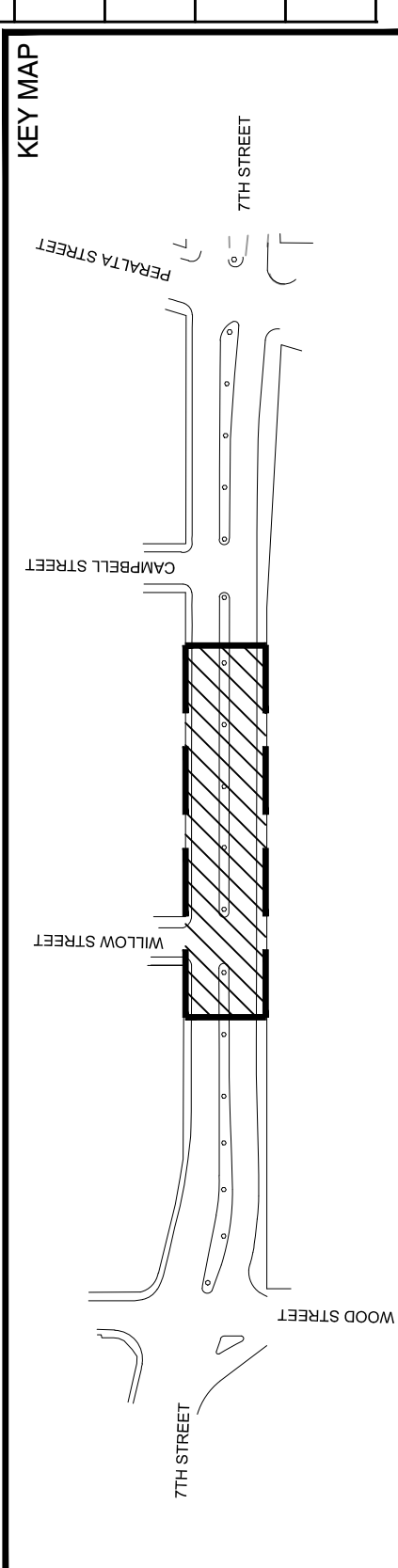

SYMBOL	KEY	DESCRIPTION	DETAIL
[Symbol]	F5	NEW PEDESTRIAN LIGHT	SEE ELECTRICAL DWGS
[Symbol]	F6	NEW STREET LIGHT	SEE ELECTRICAL DWGS
[Symbol]	F7	METAL GRATE	SEE DETAIL B, SHEET L-2.5

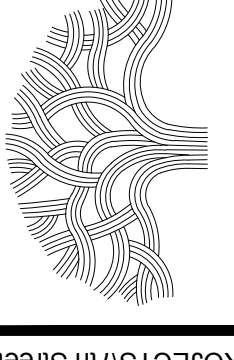

CITY OF OAKLAND
 DESIGN AND CONSTRUCTION SERVICES DEPARTMENT
 250 FRANK H. OGAWA PLAZA, SUITE 4014 • OAKLAND CA 94612
 (510) 236-5457 • FAX (510) 236-7227

7TH STREET WOTV STREETSCAPE PHASE II

LAYOUT PLAN

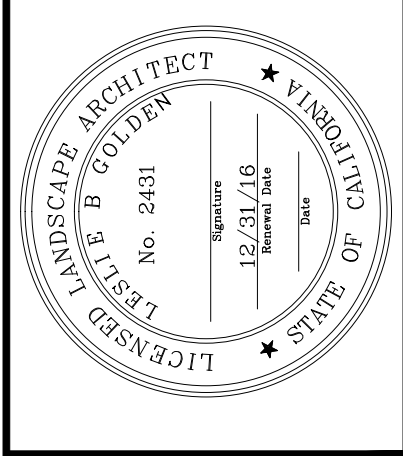

LANDSCAPE ARCHITECT	No.	DATE	BY	REFERENCE
		01-10-2014		35% CD Submittal
		10-06-2014		65% CD Submittal
		07-24-2015		95% CD Submittal

No.	DATE	BY	REFERENCE

GOLDEN ASSOCIATES
 LANDSCAPE ARCHITECTURE
 URBAN DESIGN & PLANNING
 300 FRANK H. OGAWA PLAZA, SUITE 308
 OAKLAND, CA 94612
 T: 510.465.4030
 F: 510.465.5325
 CA LIC. #9431

PROJECT NO.
G313170

95% CD NOT FOR CONSTRUCTION

SCALE: AS SHOWN
 HOR: L-2.2
 VERT: 54 OF 77
 DATE: 07/24/2015

DRAWING NAME: H:\PROJECTS\7th Street\7th-LAY.dwg
 PLOT DATE: 08-18-15
 PLOTTED BY: #

H:\PROJECTS\7th Street\7th-LAY.dwg

8/18/2015 10:53 AM

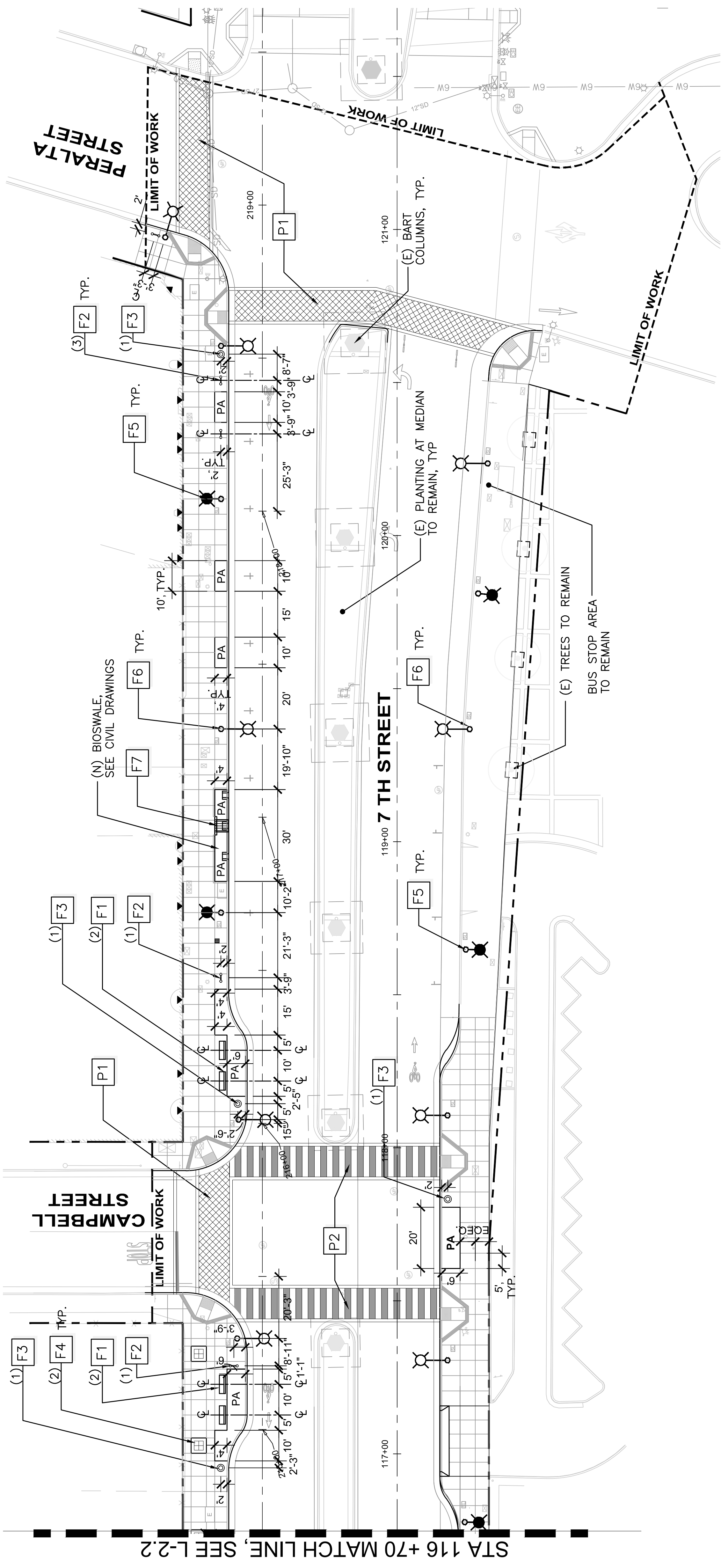

STA 116 +70 MATCH LINE, SEE L-2.2

A LANDSCAPE PLAN STA 116+70 TO STA 122+00
SCALE: 1" = 20'

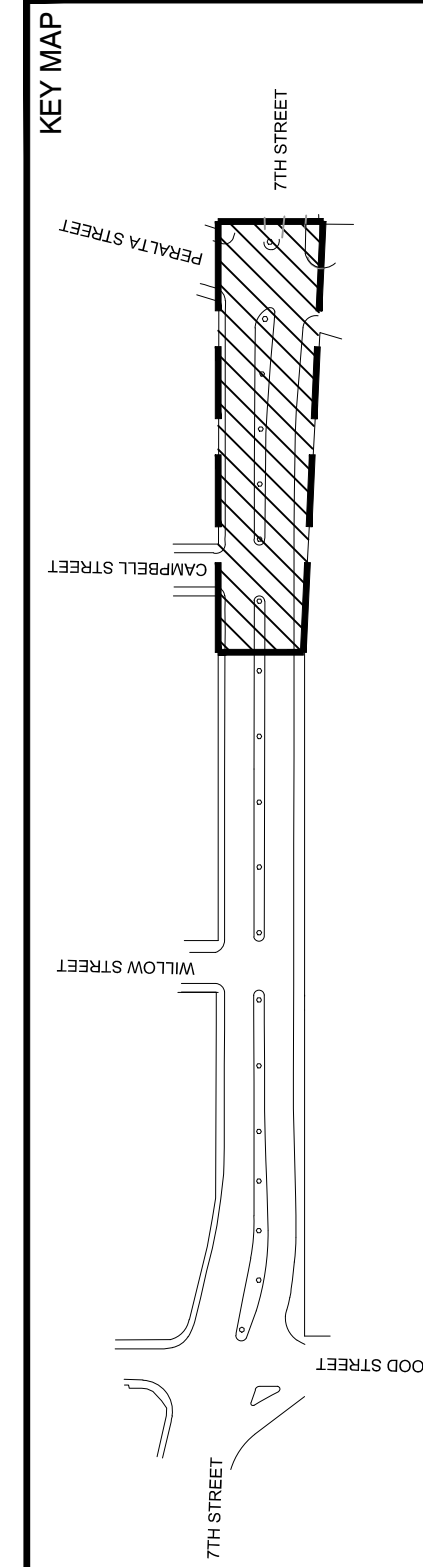

LAYOUT LEGEND

SYMBOL	KEY	DESCRIPTION	DETAIL
	P1	STAMPED ASPHALT PAVING AT CROSSWALK	SEE DETAIL B, SHEET L-2.4
	P2	NEW CROSSWALK	SEE CIVIL DWGS
	F1	BENCH	SEE DETAIL C, SHEET L-2.4
	F2	BIKE RACK	SEE DETAIL D, SHEET L-2.4
	F3	TRASH RECEPTACLE	SEE DETAIL A, SHEET L-2.5
	F4	WALK OF FAME PLAQUE	SEE DETAIL A, SHEET L-2.4

SYMBOL	KEY	DESCRIPTION	DETAIL
	F5	NEW PEDESTRIAN LIGHT	SEE ELECTRICAL DWGS
	F6	NEW STREET LIGHT	SEE ELECTRICAL DWGS
	F7	METAL GRATE	SEE DETAIL B, SHEET L-2.5

ABBREVIATION	DESCRIPTION
(E)	EXISTING
(N)	NEW
PA	PLANTING AREA
TYP.	TYPICAL
D.G.	DECOMPOSED GR

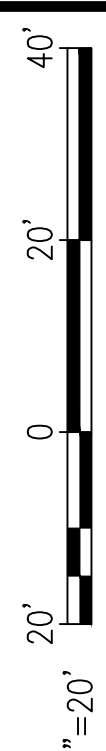
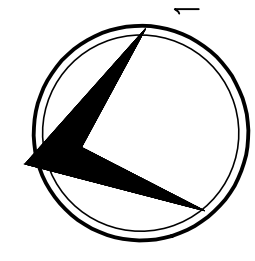

7TH STREET WOTV STREETSCAPE
PHASE II
LAYOUT PLAN

CITY OF OAKLAND
DESIGN AND CONSTRUCTION SERVICES DEPARTMENT
250 FRANK H. OGAWA PLAZA, SUITE 4014 • OAKLAND, CA 94612
(510) 238-5437 • FAX (510) 238-7227

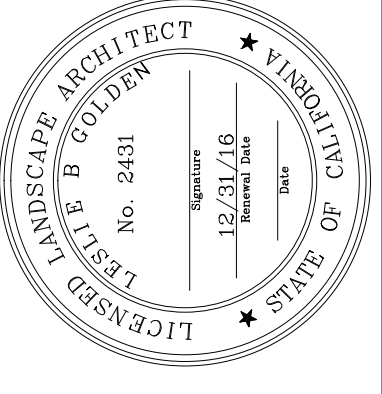

No.	DATE	BY	REFERENCE
	01-10-2014		35% CD Submittal
	10-06-2014		65% CD Submittal
	07-24-2015		95% CD Submittal

GOLDEN ASSOCIATES
LANDSCAPE ARCHITECTURE
URBAN DESIGN & PLANNING
300 FRANK H. OGAWA PLAZA, SUITE 308
OAKLAND, CA 94612
T: 510.465.4030
F: 510.465.5325
CA LIC. #8431

95% CD
NOT FOR
CONSTRUCTION

PROJECT NO.
G313170
SCALE: AS SHOWN
HOR: L-2.3
VERT: 55
DATE: 07/24/2015
SHEET NO. OF 77

40 CFR 93.126 Exempt Projects List

County	TIP ID	Sponsor	Project Name	Project Description	Expanded Description	Project Type under 40 CFR 93.126
ALA	ALA150045	AC Transit	AC Transit: PM - Exchange for 40ft Fuel Cell ZEB	AC Transit: Preventive maintenance program, including maintenance of buses and facilities. Project is in exchange for local funds to replace 10 (of 102 in sub-fleet) 40ft urban diesel buses with Zero-emission fuel cell buses	AC Transit: Preventive maintenance program, including maintenance of buses and facilities. Project is in exchange for local funds to replace 10 (of 102 in sub-fleet) 40ft urban diesel buses with Zero-emission fuel cell buses	Mass Transit - Rehabilitation of transit vehicles
ALA	ALA150049	Berkeley	goBerkeley Residential Shared Parking Pilot	In Berkeley: In residential areas adjacent to Southside/Telegraph and Elmwood goBerkeley program areas: Implement parking pricing pilot; in pilot areas: Implement TDM strategies and outreach focused on businesses and residents	In Berkeley: Non-infrastructure project. Implement parking pricing pilot programs in Residential Preferential Permit (RPP) areas adjacent to existing Southside/Telegraph and Elmwood goBerkeley areas, including comprehensive data collection using existing Automated License Plate Recognition system, extensive public outreach, introduction of a pay-by-phone payment system, and upgrades to existing parking signage. Implement targeted TDM strategies in pilot areas, including education/outreach and transit and biking incentives, focused on employees and residents in and around pilot areas.	Other - Specific activities which do not involve or lead directly to construction, such as: Planning and technical studies; Grants for training and research programs; Planning activities conducted pursuant to Titles 23 and 49 U.S.C. Federal-aid systems revisions
CC	CC-150017	San Pablo	Rumrill Blvd Complete Streets Improvements	In San Pablo: Along Rumrill Boulevard between San Pablo Avenue to the North and Costa Avenue to the South; Complete Streets Improvements and road diet	In San Pablo: Along Rumrill Boulevard, this project will calm traffic, improve the safety and appeal of walking and bicycling and enhance the appearance of the corridor for businesses, residents, and everyday travel. It will improve sidewalk and street edge with a separated space for bicyclists and landscaping, enhance multi-modal safety by reducing the number of travel lanes while maintaining capacity with left turn pockets, and provides shorter crossings with enhanced sidewalks throughout the corridor.	Air Quality - Bicycle and pedestrian facilities
SCL	SCL150017	Mountain View	Mountain View El Camino Real Streetscape Study	In Mountain View: On El Camino Real within the City Limits; Develop detailed designs for sidewalks, crosswalks, lighting, landscaping, bicycle facilities and bus stops. Project will not lead directly to construction.	In Mountain View: On El Camino Real within the City Limits; The El Camino Real Streetscape Plan will provide location-specific design for public infrastructure, including but not limited to curbs, sidewalks, bicycle lanes, street furniture, landscaping, crosswalks, medians, lighting, and way-finding signage. The plan will provide detailed direction for the City and private developers to implement the long-term vision of El Camino Real as a walkable, transit-rich and bicycle-friendly area.	Other - Specific activities which do not involve or lead directly to construction, such as: Planning and technical studies; Grants for training and research programs; Planning activities conducted pursuant to Titles 23 and 49 U.S.C. Federal-aid systems revisions
SCL	SCL150018	VTA	Peery Park Rides	In Sunnyvale: Peery Park area: Implement flexible transit service as part of a trip reduction strategy	Implement flexible transit service as part of a trip reduction strategy for Sunnyvale's Peery Park area. Project will combine flexible transit with aggressive trip reduction targets to induce demand for alternative trips for commute and non-commute trips.	Other - Transportation enhancement activities (except rehabilitation and operation of historic transportation buildings, structures, or facilities)
SF	SF-150014	SFMTA	SFMTA 30' Motor Coach Mid-Life Overhaul	SFMTA: Approximately 86 hybrid coaches: Perform midlife overhauls	Perform the midlife overhaul on approximately 86 hybrid coaches that were manufactured by Orion. The coaches were purchased in 2006 and 2007 and have reached half of their useful life. In other for the coaches to continue to operate reliably a midlife overhaul of the major components of the coaches is needed. The scope of work will include replacement or overhaul of the propulsion system, cooling system, suspension system, brake system, door system, fuel system, heating and ventilating system, wheelchair ramps, body and understructure, paint scheme, electronic equipment and piping.	Mass Transit - Rehabilitation of transit vehicles
SF	SF-150015	SFMTA	SFMTA: Replacement of 40' Trolley Coaches	SFMTA: Replace approximately 21 40' ETI electric trolley buses originally in service in 2002 with 21 40' electric trolley buses.	Replacement of approximately 21 40' ETI electric trolley buses originally in service in 2002 with 21 40' electric trolley buses. Manufacturer is New Flyer of America, Inc. Included in RTP and agency Transit Fleet Management Plan; has reasonable cost estimates. Procurement by exercising option in King County-Seattle Metro Transit contract.	Mass Transit - Purchase of new buses and rail cars to replace existing vehicles or for minor expansions of the fleet
SF	SF-150016	SF DPW	Lombard Street Vision Zero Project	In San Francisco: On Lombard/US-101 between Broderick St and Franklin St; Install curb extensions and other pedestrian safety and transit features.	In San Francisco: On Lombard/US-101 between Broderick St and Franklin St; Install curb extensions (pedestrian and transit bulbs), implement parking removal at intersections (daylighting), implement signal timing improvements, and potentially install advanced stop bars and high visibility crosswalks.	Air Quality - Bicycle and pedestrian facilities
SM	SM-110080	San Mateo Co	Alpine Road Drainage and Road Restoration	In the unincorporated Los Trancos Woods area near the Town of Portola Valley: Repair eroded Alpine Road roadway and failing culvert system. Project is funded through the Emergency Relief program	Repairs consist of reconstructing the eroded roadway and embankment using large diameter rock, soil, and baserock. The culvert will be slip-lined to restore culvert drainage capacity. Moreover, an overflow culvert will be constructed to provide auxiliary drainage if the primary culvert fails.	Other - Repair of damage caused by natural disasters, civil unrest, or terrorist acts, except projects involving substantial functional, locational, or capacity changes.
SM	SM-150012	Daly City	Daly City Central Corridor Bike/Ped Safety Imprmnt	In Daly City: On Junipero Serra Blvd and Eastmoor Ave/San Pedro Rd/E Market St/Guad Cyn Pkwy: Install bike and ped improvements; In Daly City/Uninc San Mateo County: On west side of Mission St/El Camino Real (State Route 82): install new sidewalk	In Daly City, install bicycle routes and/or lanes consisting of pavement markings and signs on Junipero Serra Blvd from City limit to City limit, Eastmoor Ave, San Pedro Rd, E Market St, Guadalupe Canyon Parkway. Additionally along these streets, install upgraded curb ramps, bulb-outs, upgraded or new pedestrian push buttons, pedestrian countdown signals, and traffic speed feedback devices at select locations. Install new sidewalk on the west side of Mission Street and El Camino Real starting near the intersection of Mission Street and San Pedro Rd in Daly City and ending at the intersection of El Camino Real and A Street in Unincorporated San Mateo County. The sidewalk work will include elements of the Grand Boulevard Initiative within Daly City, including brick banding, lighting, landscaping, irrigation, benches, and trash/recycling receptacles.	Air Quality - Bicycle and pedestrian facilities
SM	SM-150014	San Mateo County Ed	Safe Routes to School for Health and Wellness	San Mateo County: Countywide: implement a non-infrastructure educational program to increase the number of children who bike and walk to school with a focus on long term sustainability. Other State funds are Office of Traffic Safety Ped/Bike Safety grant	The merger of Safe Routes to School with education standards, the Coordinated School Health Model, and Local Control Accountability Plans will enable comprehensive Safe Routes to School safety and health education to be embedded into school curriculum, into school cultures, and into community cultures for systematic and lasting change. Alignment with existing priorities ensures that the development and implementation of sustainable Safe Routes to School programs is embraced and becomes part of the school and community culture. Under the guidance of a Program Coordinator, the result of program efforts will include development and implementation of a Health and Physical Education Kit, a Safe and Supportive School Travel Kit, and a Community Empowerment Kit that can be used in other regions as well.	Other - Specific activities which do not involve or lead directly to construction, such as: Planning and technical studies; Grants for training and research programs; Planning activities conducted pursuant to Titles 23 and 49 U.S.C. Federal-aid systems revisions
SM	SM-150016	San Mateo	San Mateo Downtown Parking Tech Implementation	In San Mateo: Various Locations Downtown: Replace existing parking meters, and pay stations and install parking availability signs at City facilities.	In San Mateo: El Camino Real to Delaware; 9th Avenue to Tilton: Replace old meters with smart meters utilizing existing bases, poles and conduit. Install parking availability signs at City facilities using existing conduit.	Other - Directional and informational signs
SOL	SOL150004	STA	STA SR25 Infrastructure & Non-Infrastructure	Solano County: At 7 schools: Implement pedestrian infrastructure improvements; At 26 schools throughout the Cities of Benicia, Rio Vista & Vallejo: Providing education outreach	This combined infrastructure and non-infrastructure Safe Routes to Schools project, provides for infrastructure improvements at 7 schools, while providing education outreach to 26 schools throughout the Cities of Benicia, Rio Vista & Vallejo. Three project sites in Vallejo and five project sites in Benicia.	Air Quality - Bicycle and pedestrian facilities



METROPOLITAN
TRANSPORTATION
COMMISSION

Joseph P. Bort MetroCenter
101 Eighth Street
Oakland, CA 94607-4700
TEL 510.817.5700
TDD/TTY 510.817.5769
FAX 510.817.5848
E-MAIL info@mtc.ca.gov
WEB www.mtc.ca.gov

Memorandum

TO: Air Quality Conformity Task Force

DATE: March 24, 2016

FR: Adam Crenshaw

RE: Review of the Regional Conformity Status for New and Revised Projects

Staff has prepared the following information in an effort to streamline the review of the regional air quality conformity implications of projects that staff proposes to revise or add into the 2015 TIP through current or future revisions. This item is for advisory purposes only. The inclusion of these projects and project changes in a proposed revision to the TIP is subject to Commission approval in the case of amendments and MTC's Executive Director or Deputy Executive Director in the case of administrative modifications. The final determination of the regional air quality conformity status of these projects will be made by the Federal Highway Administration, the Federal Transit Administration and the Environmental Protection Agency as part of their review of proposed final TIP amendments and by the Executive Director or Deputy Executive Director as part of their review for TIP administrative modifications.

Projects Staff is Proposing to Include in the 2015 TIP

Staff has received requests from sponsors to add three new individually listed projects and four new group listed projects to the 2015 TIP.

Two of the proposed new individually listed projects include elements that may not be treated as exempt from regional-level conformity under 40 CFR 93.126 or 40 CFR 93.127. However, staff believes that the addition of these projects to the 2015 TIP would not require an update to the air quality conformity analysis for *Plan Bay Area* and the 2015 TIP. The projects are as follows:

1. Rumrill Blvd Complete Streets Improvements

TIP ID: CC-150017

Sponsor: City of San Pablo

Description: In San Pablo: Along Rumrill Boulevard between San Pablo Avenue to the North and Costa Avenue to the South: Implement complete streets improvements and road diet

Expanded Description: In San Pablo: Along Rumrill Boulevard, this project will calm traffic, improve the safety and appeal of walking and bicycling and enhance the appearance of the corridor for businesses, residents, and everyday travel. It will improve sidewalk and street edge with a separated space for bicyclists and landscaping, enhance multi-modal safety by reducing the number of travel lanes while maintaining capacity with left turn pockets, and provides shorter crossings with enhanced sidewalks throughout the corridor.

Conformity Issue: This project includes a road diet in the project area and cannot be considered exempt from regional air quality conformity analysis. However, the project location has an estimated AADT of approximately 19,000 vehicles and, as such, staff is requesting the Task Force's concurrence that the project should be deemed Non-Exempt,

Not Regionally Significant and that the addition of this project to the 2015 TIP would not require an update to the regional air quality conformity analysis.

2. US 101 HOV/HOT from Santa Clara to I-380

FMS ID: 6205.00

Sponsor: San Mateo C/CAG

Description: In San Mateo County: On US 101 between the Santa Clara County Line and I-380: Install an HOV/Express Lane.

Expanded Description: On US 101 between the Santa Clara County Line and I-380, install an HOV/Express Lane. Utilize existing auxiliary lanes where possible and restore auxiliary lanes where needed for operations.

Conformity Issue: Neither the addition of HOV lanes or express lanes are exempt from regional air quality conformity analysis under 40 CFR 93.126 or 40 CFR 93.127. As such, staff proposes to add this project to the 2015 TIP as a regionally non-exempt project.

However, staff is proposing to add only the preliminary engineering phase of this project to the active years of the 2015 TIP at this time. The remaining phases of the project will be programmed in fiscal year 2018-19, outside of the active years of the TIP, for informational purposes only. A portion of this project is currently modelled as complete by the end of calendar year 2020 for regional air quality conformity purposes and the remainder is expected to be completed between 2021 and 2030. As PE is not a capital phase and the programming of the remainder of the project in 2019 does not conflict with current model used for the regional air quality conformity analysis, staff is requesting the Task Force's concurrence that the addition of this phase to the active years of the 2015 TIP will not require an update to the air quality conformity analysis.

The capital phases of this project are expected to enter the active years of the TIP through a future update or revision. This project will be brought back to the Task Force for consultation on its regional air quality conformity implications again at that time.

Attachment A includes a list of the remaining five projects along with the regional air quality category that staff believes best describes the projects.

MTC staff is not seeking a determination on the status of these projects for project-level conformity purposes with this item.

Item 3a - Attachment A						
County	TIP ID/FMS ID	Sponsor	Project Name	Project Description	Project Expanded Description	Project Type
Proposed New Individually Listed Projects for Regional Air Quality Conformity Status Review						
San Francisco	TBD	Central Federal Lands Highway Division	CA FLAP SF TR95(1) SOUTH OCEAN BEACH TRAIL	San Francisco: South Ocean Beach: Construct a multi-use trail and active transportation facility	San Francisco: South Ocean Beach: Construct a multi-use trail and active transportation facility	EXEMPT (40 CFR 93.126) - Bicycle and pedestrian facilities
Proposed New Group Listed Projects for Regional Air Quality Conformity Status Review						
Alameda	TBD	Central Federal Lands Highway Division	CA FTFW/FLAP DOED 10(3) LA RIVIERE MARSH BRIDGE & MARSHLANDS ROAD	Reconstruct 0.5 mile from Thornton Avenue to Don Edwards NWR visitor center and replace LaRiviere Marsh Bridge.	Reconstruct 0.5 mile from Thornton Avenue to Don Edwards NWR visitor center and replace LaRiviere Marsh Bridge.	EXEMPT (40 CFR 93.126) - Pavement resurfacing and/or rehabilitation
Marin	TBD	Central Federal Lands Highway Division	CA FTNP GOGA PRES 1(15) GOLDEN GATE NRA TUNNEL PRESERVATION	Repair Baker Barry Tunnel Lining	Repair Baker Barry Tunnel Lining	EXEMPT (40 CFR 93.126) - Pavement resurfacing and/or rehabilitation
Marin	TBD	Central Federal Lands Highway Division	CA FLAP MRN CR107(1) MUIR WOODS ROAD	Rehabilitation of a 2.48 mile long segment of Muir Woods Road that connects the national park entrance to CA Highway 1.	Rehabilitation of a 2.48 mile long segment of Muir Woods Road that connects the national park entrance to CA Highway 1.	EXEMPT (40 CFR 93.126) - Pavement resurfacing and/or rehabilitation
San Mateo	VAR110012	East Palo Alto	Grouped Listing - Safe Routes to School	Fordham St. between Notre Dame Ave. and Purdue Ave.; Bay Rd. between Newbridge St. and SR 109 (University Ave.); Pulgas Ave./Runnymede St.; Pulgas Ave. between O'Conner St. and Myrtle St.: Construct sidewalks, curbs and gutters; install LED in-pavement crosswalk lights	Fordham St. between Notre Dame Ave. and Purdue Ave.; Bay Rd. between Newbridge St. and SR 109 (University Ave.); Pulgas Ave./Runnymede St.; Pulgas Ave. between O'Conner St. and Myrtle St.: Construct sidewalks, curbs and gutters; install LED in-pavement crosswalk lights	EXEMPT (40 CFR 93.126) - Bicycle and pedestrian facilities

J:\SECTION\PLANNING\AIRQUAL\TSKFORCE\2016\1-28-16\Draft\3a_Attachment-A_List_of_Proposed_New_Projects_1-28-15.xlsx]Sheet1

**Air Quality Conformity Task Force
Summary Meeting Notes
February 25, 2016**

Participants:

Kristen Johnson – HNTB

Chadi Chazbek – HNTB

Rodney Tavitas – Caltrans

Ginger Vagenas – EPA

Ted Mately – FTA

Amir Fanai – BAAQMD

Andrea Gordon – BAAQMD

Dick Fahey – Caltrans

Scott Lane – MTC Policy Advisory Council

Chris Lillie – BATA

Darryl Yip – MTC

Adam Crenshaw – MTC

Harold Brazil – MTC

1. Welcome and Self Introductions: Harold Brazil (MTC) called the meeting to order at 9:35 am.

2. PM_{2.5} Project Conformity Interagency Consultations

a. Consultation to Determine Project of Air Quality Concern Status

i. Richmond-San Rafael Bridge Access Improvement Project

Chadi Chazbek (HNTB) began his description of the Richmond-San Rafael Bridge Access Improvement project by stating that the project would construct a Peak Period Use Lane (PPUL) on the Richmond-San Rafael Bridge by converting eastbound existing shoulder. Mr. Chazbek added that the project also construct a Class I bi-directional bike/pedestrian path on the Bridge with the inclusion of an 18" moveable barrier.

Mr. Chazbek indicated that the purpose of the Richmond-San Rafael Bridge Access Improvement project is to:

- Reduce congestion and delay (address the bottleneck in traffic in the eastbound direction)
- Improve evening commute periods
- Provide bike and pedestrian access across the Richmond-San Rafael Bridge
- Provide access to the San Francisco Bay Trail on either side of the Bridge

Mr. Chazbek stated the project background status and schedule as follows:

- Added to the 2015 TIP (September 2015)
- Seeking air quality conformity determination on or before (February 2016)
- Categorical Exemption/Categorical Exclusion (CE/CE) to be completed in June 2016
- No public outreach or review required under a CE/CE
- Anticipated construction start date (September 2016)

Mr. Chazbek also mentioned that the Richmond-San Rafael Bridge Access Improvement project will close the gap on the San Francisco Bay Trail, the public outreach component of the project's

development went well and construction on the project should take about one year opening for traffic in the fall of 2017.

Dick Fahey (Caltrans) asked about the traffic patterns in the project area noted in the project assessment form for commuters traveling to and from San Francisco and mentioned that he wasn't sure how this project would benefit commuters making this trip. Mr. Chazbek responded by stating that the text in the assessment form should be clarified to say that the majority of the commuter traffic involves trips to and from Marin and Contra Costa Counties.

Scott Lane (MTC Policy Advisory Council) asked if there were any thoughts about converting the added lane from the project to an express/carpool lane to provide as an incentive for commuters to leave their cars at home.

Chris Lillie (BATA) replied by saying that there was some initial discussion on this subject and due to the additional lane being a short length segment, there would be less of an opportunity to effect driver behavior. Also, Mr. Lillie mentioned that after the 4-year project pilot time period ends, the intent is to adjust how the added lane operates in the future.

Ginger Vagenas (EPA) did not feel that the Richmond-San Rafael Bridge Access Improvement project was of air quality concern, but commented that the project assessment form needed to be revised to remove any "bright line" AADT and/or diesel traffic threshold level reference and to clarify the assessment form's statement in reference to the region attaining 24-hour PM_{2.5} National Ambient Air Quality Standard (NAAQS). Rodney Tavitas (Caltrans) agreed with Ms. Vagenas and also did not feel the project was of air quality concern, but recommended the project sponsor revise the assessment form to reflect the November 2015 EPA PM hotspot guidance. Mr. Chazbek and Kristen Johnson (HNTB) agreed to make the revisions to the project assessment form.

Final Determination: With input from FTA, EPA, Caltrans and FHWA (via email), the Task Force concluded that the Richmond-San Rafael Bridge Access Improvement project was not of air quality concern.

b. Confirm Projects Are Exempt from PM_{2.5} Conformity

i. Confirmation of the list of exempt projects from PM_{2.5} conformity (2b_Exempt List 021116.pdf)

Ginger Vagenas (EPA) and Rodney Tavitas (Caltrans) stated that TIP ID number **SON130012** the Conde Lane/Johnson St Pedestrian Improvements project needed to be removed from the 2b_Exempt List 021116.pdf list of exempt projects due to the signalization component of the project.

Final Determination: With input from FHWA (via email), FTA, EPA, Caltrans and MTC, the Task Force agreed, with the exclusion of projects **SON130012**, that the rest of the projects on the exempt list (**2b_Exempt List 021116.pdf**) were exempt from PM_{2.5} project level analysis.

3. Projects with Regional Air Quality Conformity Concerns

a. Review of the Regional Conformity Status for New and Revised Projects

Projects Staff Proposing to Include in the 2015 TIP

Adam Crenshaw (MTC) stated that MTC staff has received requests from sponsors to add 30 new individually listed projects to the 2015 TIP. Mr. Crenshaw stated that two of the proposed new individually listed projects include elements that may not be treated as exempt from regional-level conformity under 40 CFR 93.126 or 40 CFR 93.127, but Mr. Crenshaw went on to say that MTC staff believes that the projects are not regionally significant. The projects are as follows:

- 1. Oakland: Telegraph Ave Complete Streets (FMS ID: 6276.00)**
- 2. Peery Park Rides (FMS ID: 6274.00)**

Mr. Crenshaw requested Task Force's concurrence that the projects above may be deemed Non-Exempt, Not Regionally Significant for regional conformity purposes and that the addition of these projects to the 2015 TIP would not require an update to the Air Quality Conformity Analysis as they would not affect the regional transportation model used in analyzing regional air quality conformity. Mr. Crenshaw received no questions or comments and the Task Force concurred on this agenda item.

4. Consent Calendar

a. January 28, 2016 Air Quality Conformity Task Force Meeting Summary

Final Determination: With input from all members, the Task Force concluded that the consent calendar was approved.