



# SAN FRANCISCO-OAKLAND BAY BRIDGE (SFOBB) METERING LIGHTS SYSTEM UPGRADE PROJECT

24<sup>TH</sup> ANNUAL ITS CALIFORNIA CONFERENCE  
OCTOBER 1, 2018

# Presentation Outline

- Introduction and Background
- Project Objectives and Scope
- Existing System
- Simulation Modeling
- Proposed System
- Project Challenges
- Project Status

## SAN FRANCISCO - OAKLAND BAY BRIDGE

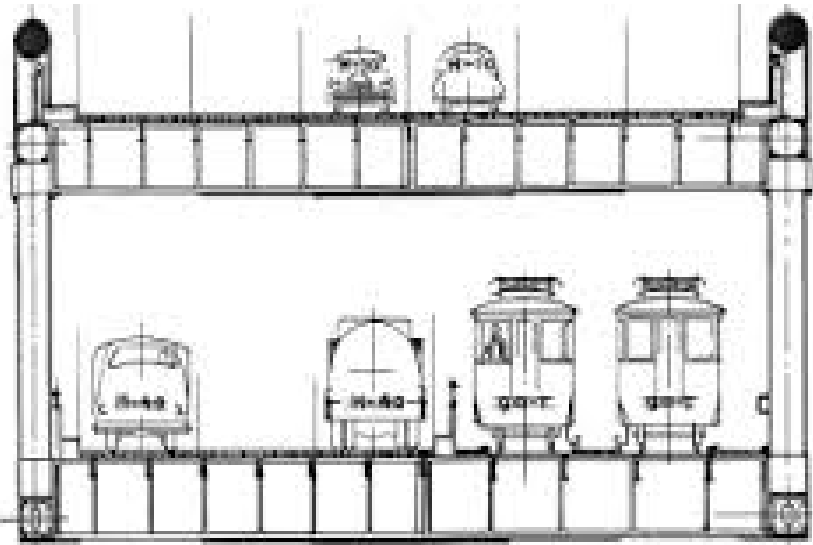

SAN FRANCISCO - OAKLAND BAY BRIDGE

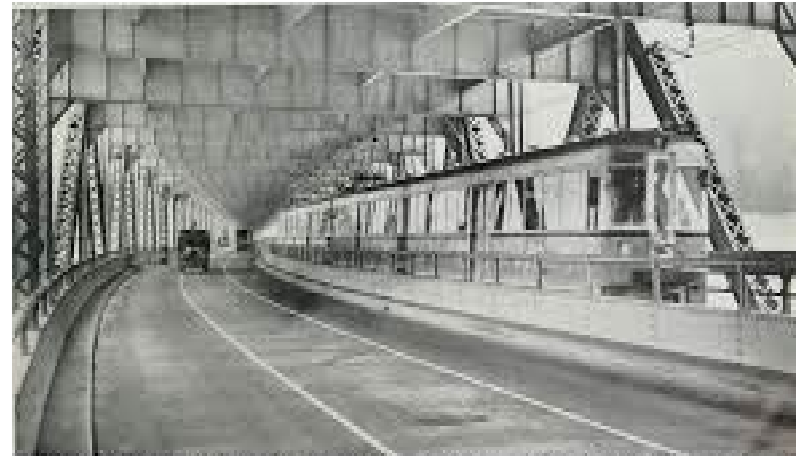

Historical Photo Showing Railroad On Lower Deck  
Source: California Highways and Public Works Magazine, Digitized By Internet Archive.

### A Few Bridge Facts:

- 1936 Bridge opens to traffic
- 1958 Bridge lanes reconfigured (vehicles/upper and lower decks)
- 1974 metering sys installed to regulate traffic on the Bridge
- 2013 East Span Bridge open to vehicles



# Toll Plaza Background

130,000 to 140,000 vehicles per day

Toll plaza has 20 approach lanes:

- 16 cash/ FasTrak® lanes
- 2 dedicated FasTrak®/ORT lanes
- 2 dedicated bus-only/HOV lanes

Metering Lane Configuration:

- 20 toll lanes converge to 16 lanes at metering lights approximately 1,000 feet west of the toll plaza
- 16 metered lanes further converge to 5 lanes across the bridge
- During HOV hours, **12 metered lanes converging to 4 lanes** on bridge – 2 bus only lanes not metered that converge to 1 lane on bridge



Toll Plaza at 5:20am

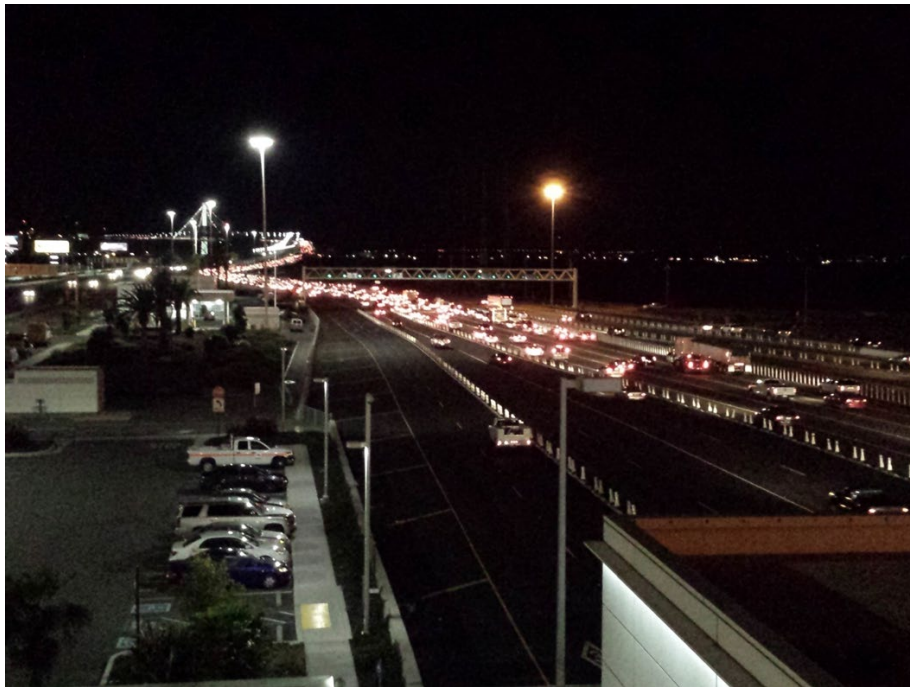

Toll Plaza at 5:30am





# Metering Lights Approach



# Existing Metering Lights System

- System first deployed in 1974
- Basically the same metering system with few technology upgrades
- Metering rates are manually controlled and implemented from the District 4 TMC
- Not capable of automatically responding to changes in traffic conditions and queuing
- The back up system is to conduct manual operations from the controller cabinets in the field





# Project Objectives

Implement a metering system that:

- optimizes the bridge's current capacity
- adapts to changing traffic conditions(i.e. accidents, reoccurring and non-reoccurring)
- reduces queuing at the toll plaza
- accommodates differential metering rates for different lane configurations and classes of users (buses, HOV, FasTrak<sup>®</sup>, and cash lanes)
- improves traffic operations and vehicle flow along the corridor
- provides for redundancy in the event of component failures



# Scope of Work Overview

- Replace and upgrade the existing metering system software and hardware system (cabinets, controllers, servers, CMS, etc.)
- Implement a fully automated and adaptive mainline metering system algorithm
- Provide redundancy via a backup TMC at the Toll Plaza Building
- Upgrade associated communications network and vehicle detection systems
- District 4 ATMS integration (ML System, CMS, loop detectors, CCTV)
- Utilize existing traffic monitoring stations in the vicinity of the Toll Plaza
- Repair or close existing gaps in the communications system



# Project Flow Overview

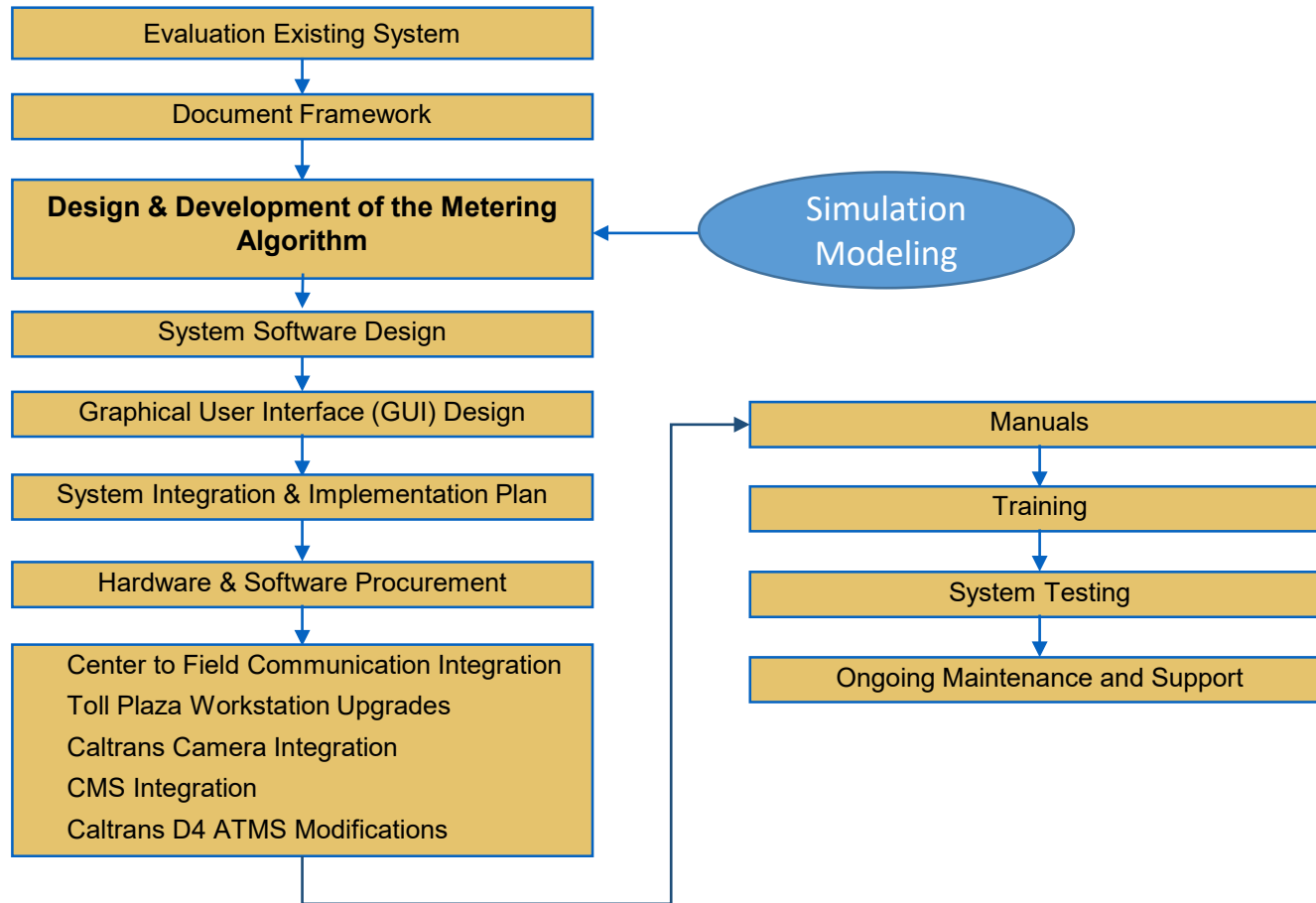



# Data Collection

- Toll Volume (BATA)
- Traffic Volume (Caltrans)
- Metering Logs (Caltrans)
- Travel Time/Delay – collected in 2016 and 2017



# Existing Traffic Volumes

## Toll Plaza Volumes

### SFOBB Flow Rate at Toll Plaza

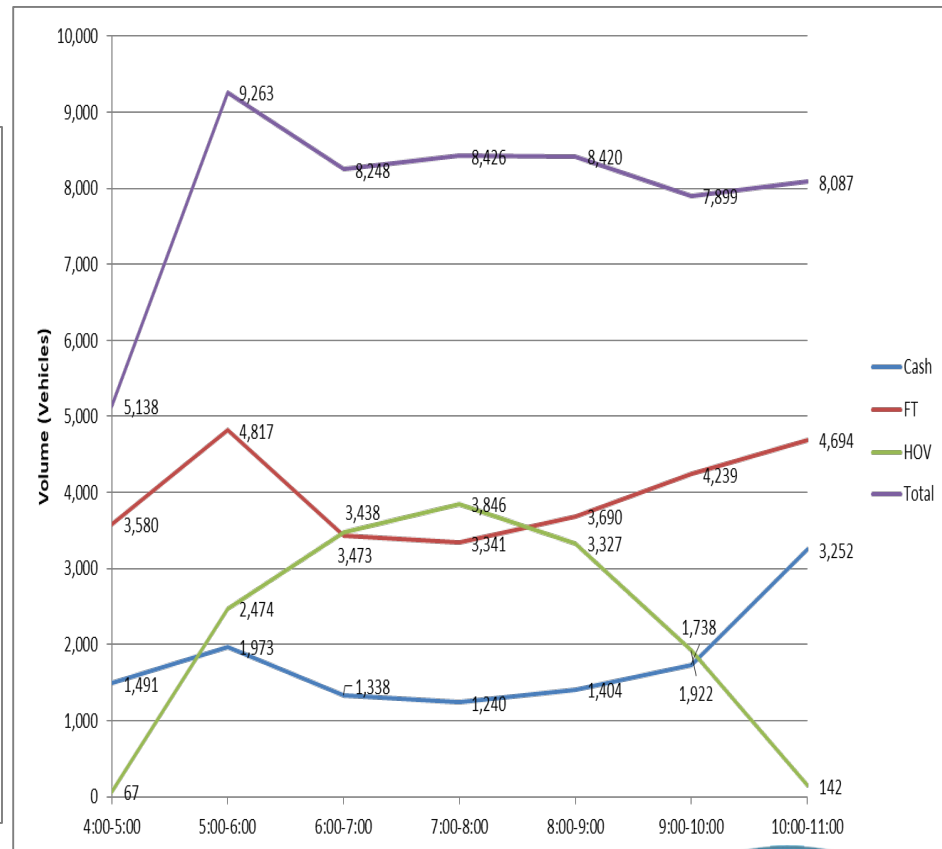
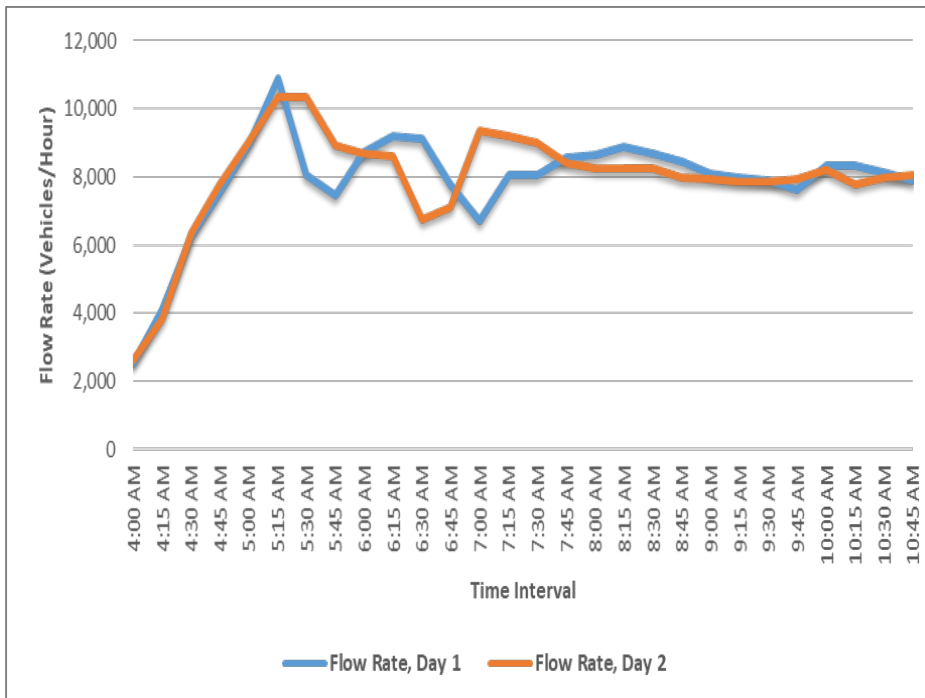

# Metering Logs

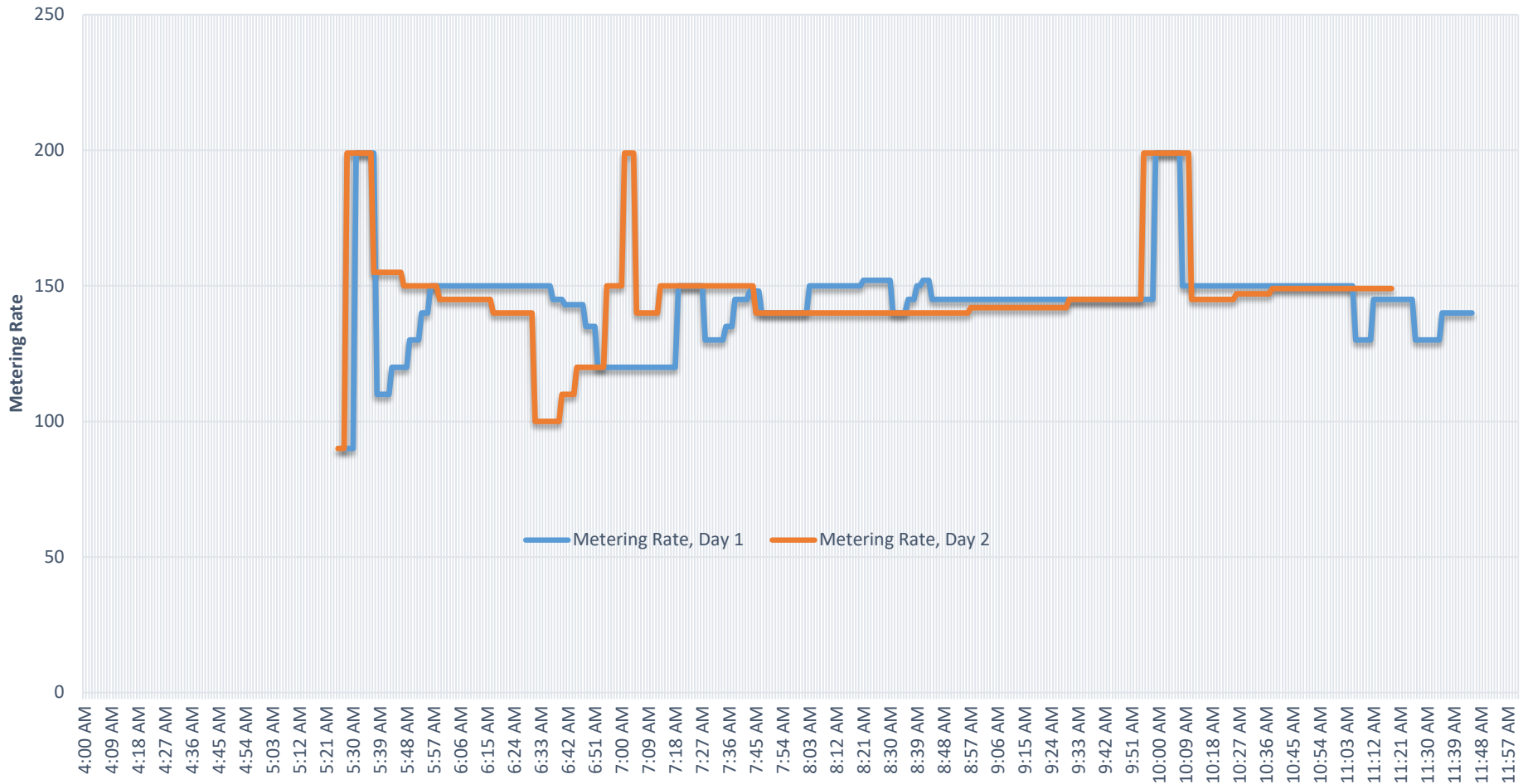

# Simulation Modeling Process

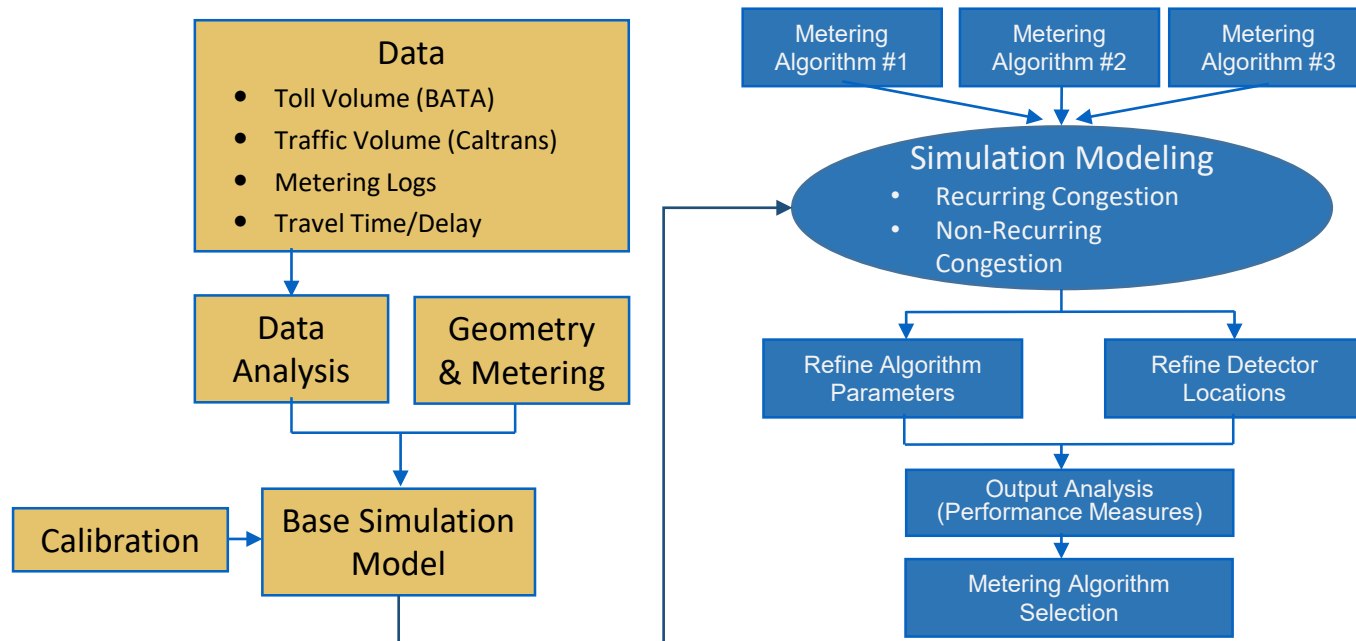



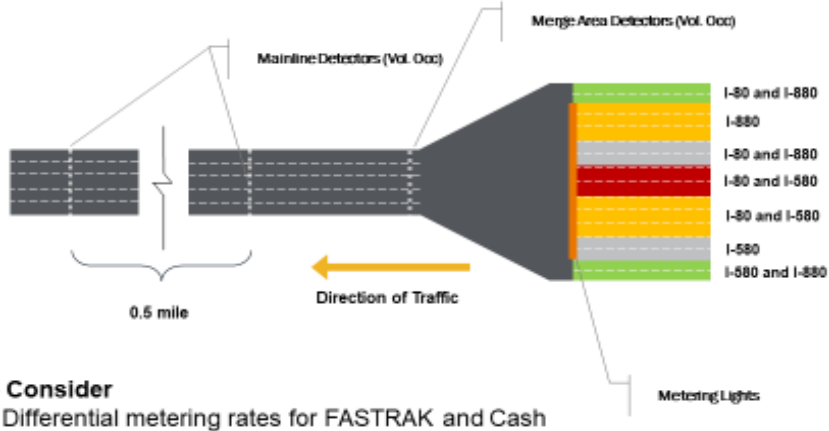

## Physical and Operational Considerations

### To Consider

- Differential metering rates for FASTRAK and Cash
- Lane assignment based by TOD
- Traffic condition on the bridge
- Traffic condition at the merging area
- Traffic condition upstream and detectors

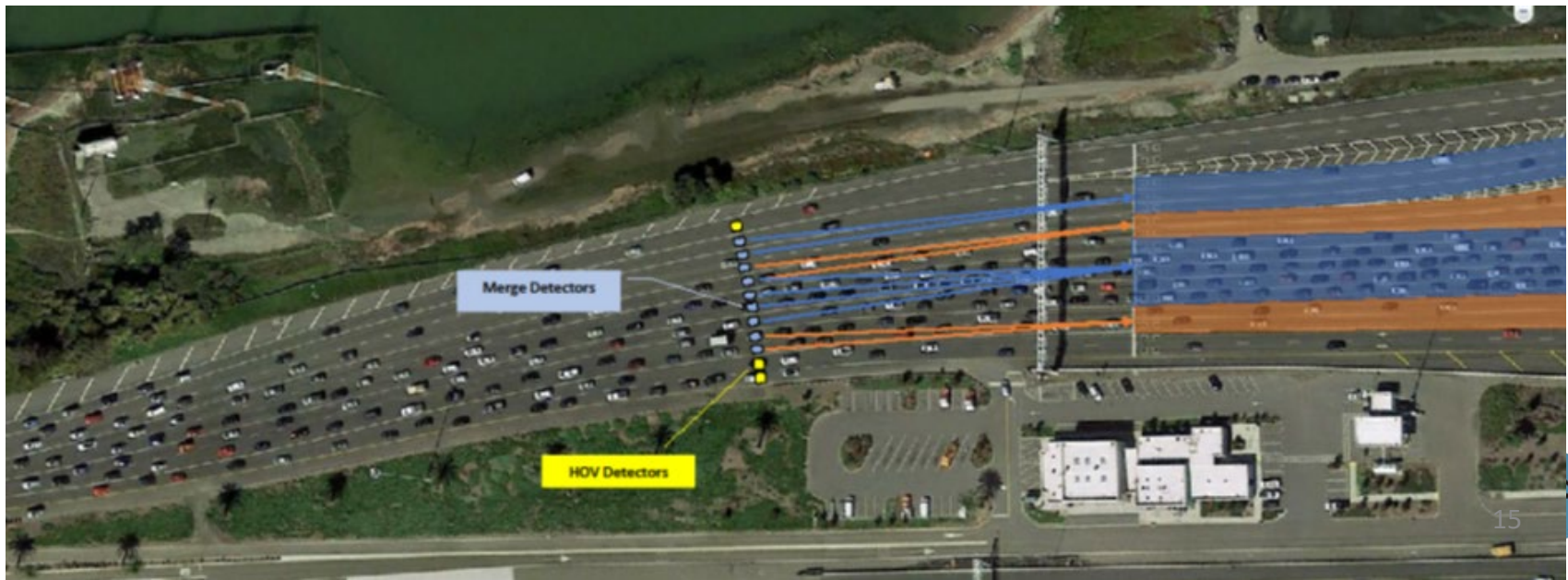

# Metering Lights Algorithm Performance Measures

- Throughput
- Travel Time
- Delay
- Recurrent Congestion
- Non-Recurrent Congestion

# Simulation Results (Recurring Congestion)

Algorithm	Throughput	Improvement	Delay	Improvement	Travel time	Improvement
Existing	41099	--	10.54	--	24.23	--
Alinea	44059	7.2%	7.3	30.7%	18.14	25.1%
PI-Alinea	43919	6.9%	7.29	30.8%	18.1	25.3%
Fuzzy #1	43771	6.5%	7.04	33.2%	16.53	31.8%
Fuzzy #2	44293	7.8%	8.06	23.5%	19.22	20.7%



# Simulation Results (Non-Recurring Congestion)

Non-Recurring (1 lane blockage)						
Algorithm	Throughput	Impact	Delay	Impact	Travel time	Impact
Existing	--	--	--	--	--	--
Alinea	43192	5.1%	7.0	--	--	--
PI-Alinea	42102	2.4%	10.0	--	--	--
Fuzzy #1	42754	4.0%	7.0	--	--	--
Fuzzy #2	44242	7.6%	8.0	--	--	--

Scenario No.	Accident Location	Number of Lanes Closed	Duration of Lane Closure	Time of Day
1	Near YBI Tunnel	1	30	8:00-8:30 AM
2	Near YBI Tunnel	2	90	6:00-7:30 AM
3	Near YBI Tunnel	3	35	6:55-7:30 AM
		2	15	7:30-7:45 AM
		1	30	7:45-8:15 AM
30				7:45-8:15 AM

Non-Recurring (3 lane blockage)						
Algorithm	Throughput	Impact	Delay	Impact	Travel time	Impact
Existing	--	--	--	--	--	--
Alinea	39158	-4.7%	11.0	-14.1%	33.29	-37.4%
PI-Alinea	38269	-6.9%	12.0	-5.8%	28.15	-16.2%
Fuzzy #1	38375	-6.6%	10.0	2.3%	25.57	-5.5%
Fuzzy #2	39447	-4.0%	11.0	-9.2%	29.02	-19.8%

Non-Recurring (3 lane blockage)						
Algorithm	Throughput	Impact	Delay	Impact	Travel time	Impact
Existing	--	--	--	--	--	--
Alinea	39650	-3.5%	12.03	-14.1%	33.29	-37.4%
PI-Alinea	39210	-4.6%	11.15	-5.8%	28.15	-16.2%
Fuzzy #1	39363	-4.2%	10.3	2.3%	25.57	-5.5%
Fuzzy #2	39983	-2.7%	11.51	-9.2%	29.02	-19.8%



## System Block Diagram

**LEGEND**

- Existing Element
- New Element
- Upgraded Existing Element
- Existing Communications Link
- New Communications Link (Primary)
- New Communications Link (Backup)

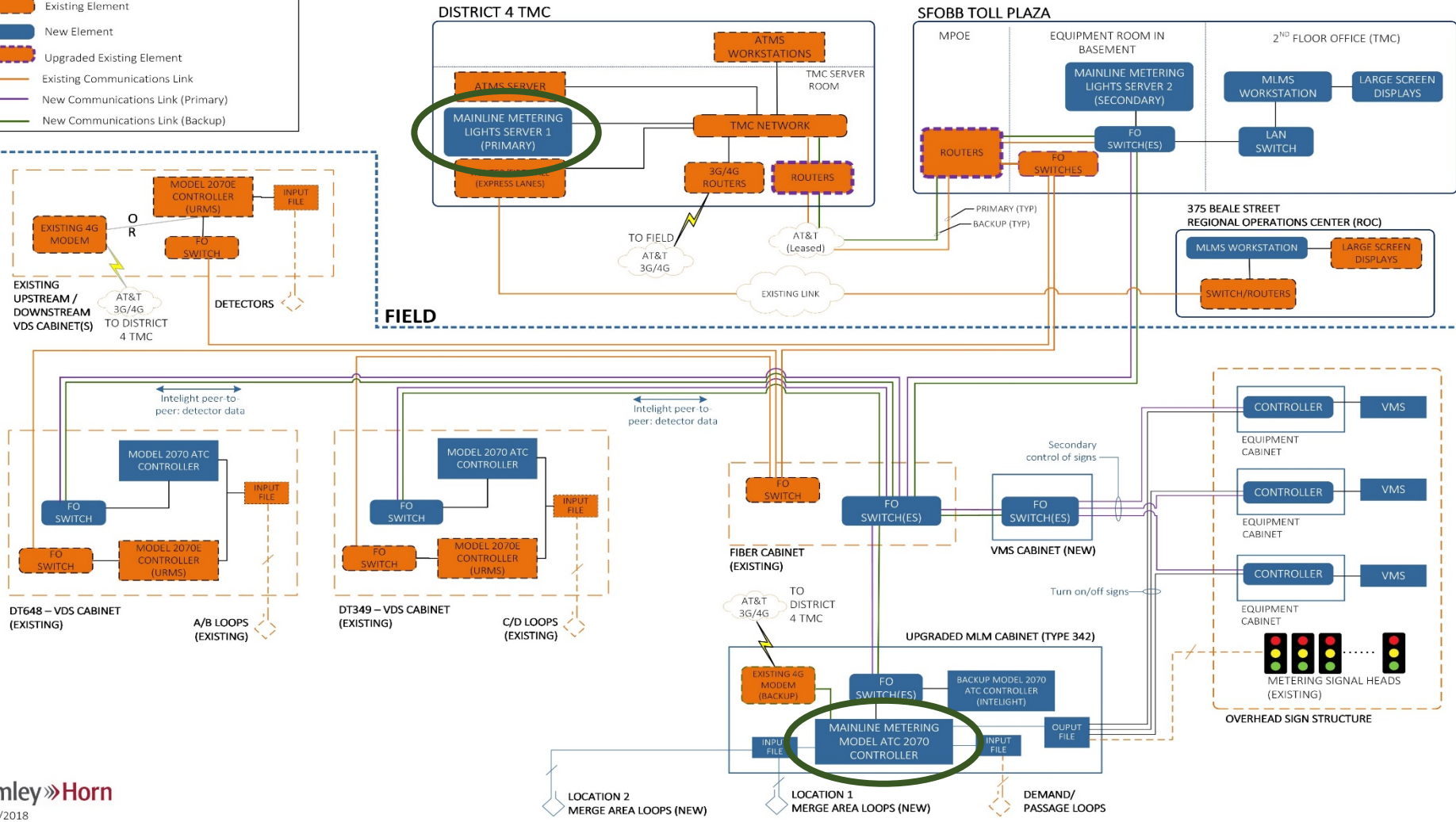

# Mainline Metering Controller Firmware

## Minimum Requirements

1. Independently control up to 16 metered lanes
2. Open interface for control from central system
3. Supports national standard (i.e., NTCIP)
4. Support for Local Traffic Responsive mode by time of day
5. Support logging volume, occupancy and speed data to the local controller database
6. Provide reporting capability - status, collected data, health
7. Pre-configured or user defined cabinet support



# Software/Firmware Candidates



Controller Software/ Firmware	Max Metered Lanes Supported	NTCIP (Y/N)
<b>Western Systems / Siemens</b>		
SEPAC - Local Controller Software	16	YES
<b>Wapiti Micro Systems</b>		
W5-ACS - Adaptive Control Software	16	YES
<b>Intelight</b>		
Intelight MaxTime Ramp Meter	16	YES
<b>Econolite/Safetran</b>		
ASC/3-2070 Controller Software	4 Meters x 4 Controllers	YES
<b>Trafficware/Naztec</b>		
SynchroGreen	4 Meters x 4 Controllers	YES
<b>McCain</b>		
Omni eX Software	4 Meters x 4 Controllers	YES



# Proposed System

- Metering Lights Server - Fuzzy Logic #1
- Metering Lights Controller - ATC 2070 with Intelight Firmware
- NTCIP 1207 (ramp meter systems) and 1209 (transportation sensor systems)
- Merge Area Detection (direct connect)
- Lane Group Metering Rate by Metering Lights Server
- Metering Rate implementation by Metering Lights Controller

# Systems Engineering Process

Phase -1	Phase 0	Phase 1	Phase 2	Phase 3	Phase 4	Phase 5
Interfacing with Planning and the Regional Architecture	Concept Exploration and Benefits Analysis	Project Planning and Concept of Operations Development	System Definition and Design	System Development and Implementation	Validation, Operations and Maintenance, Changes & Upgrades	System Retirement / Replacement

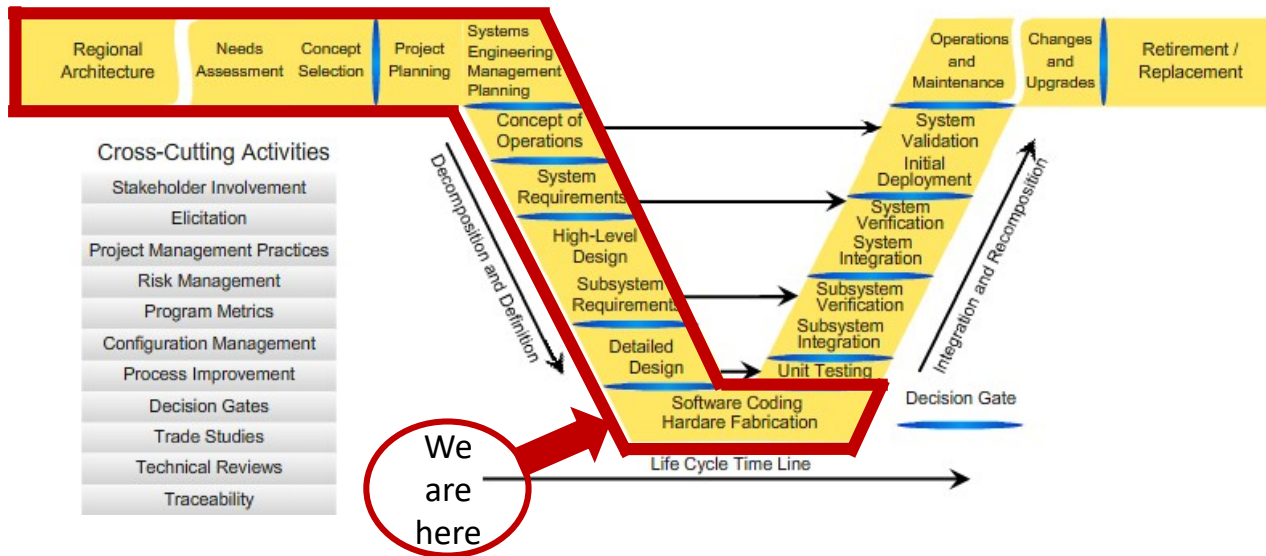



# Project Challenges

- Technical Complications
  - Replacing/Enhancing five interconnected systems
    - Metering Lights System Software
    - Controller Firmware
    - Changeable Message Signs
    - Communications
    - Detection
  - No other examples in the world
  - Lane assignments (Fastrak, cash, HOV)
  - "Merge" area
- System Cutover
  - Redundant Systems
  - Significant Testing/Burn-in Period

# Key Activities Remaining

- Design and Development of Firmware **in progress**
- Detailed Design (PS&E) **in progress**  
**70% done**
  - Additional Detection
  - Communications infrastructure
  - CMS installation
  - TMC in Toll Plaza Building
- Caltrans Encroachment Permit (PEER) **in progress**
- Environmental Revalidation **winter 2018**
- Prepare Integration, Implementation and Cutover Plans **in progress**
- CMS Procurement **early summer 2019**
- BCDC Permits
- Construction Manager Procurement **early summer 2019**
- Construction and Implementation **early summer 2019**
  - System Testing
  - Training
- Ongoing Maintenance & Support

Questions?





# SAN FRANCISCO-OAKLAND BAY BRIDGE (SFOBB) METERING LIGHTS SYSTEM UPGRADE PROJECT

24<sup>TH</sup> ANNUAL ITS CALIFORNIA CONFERENCE  
OCTOBER 1, 2018

# Algorithms Considered

		Old Algorithm	ALINEA	PI-ALINEA with RBL	Bottleneck	CARMA	COMPASS	Fuzzy Logic Caltrans	Fuzzy Logic (Chen et.al)
<b>Conditions considered</b>	Downstream	×	×	✓	✓	✓	✓	✓	✓
	Local	×	✓	✓	✓	×	✓	✓	✓
	Ramp	×	×	×	×	×	✓	✓	×
<b>Measure</b>	Volume	HOV Lanes	local	×	downstream	×	upstream	×	×
	Occupancy	local	local	Local/downstream	local	×	downstream/ramp/local	Local/ramp	Local/downstream
	Speed	×	×	×	×	downstream	×	Local/downstream	×
<b>Approach</b>		Operates at a predefined capacity based on measured HOV lanes flow	Maintains the merge area occupancy below a critical value using a feedback mechanism	Adjusts metering rates to maintain occupancies of local and several downstream stations below critical values using a feedback mechanism	Adjusts metering rates using offline optimized rates for local condition, and using a feedback mechanism considering downstream capacity	Adjusts metering rates based on downstream speed	Adjusts metering rates based on offline optimized rates	Adjusts metering rates considering local speed and occupancy, downstream speed, and upstream occupancy	Adjusts metering rates considering local and downstream occupancies
<b>Extendible to mainline metering</b>		✓	✓	✓	✓	×	✓	✓	✓
<b>Sufficient information available</b>		✓	✓	✓	✓	✓	×	✓	×
<b>Recommended for Evaluation</b>		Yes	Yes	Yes	Yes	No	No	Yes	No
<b>Rationale</b>		Base line algorithm	Robust algorithm based on feedback control.	Extension of ALINEA which considers the downstream capacity (traffic condition on the bridge)	Two level optimization technique as combination of offline rates and feedback mechanism	Only based on downstream speed	Requires calibration of a lookup table based on detector inputs from three different locations. Limited information is available on the algorithm	Rule-based algorithm based on natural language. Considers the downstream, ramps, and local conditions. Flexibility to add/evaluate additional rules	Similar to Fuzzy Logic Caltrans but does not consider ramps conditions. Limited information is available on the algorithm

## Existing System Elements

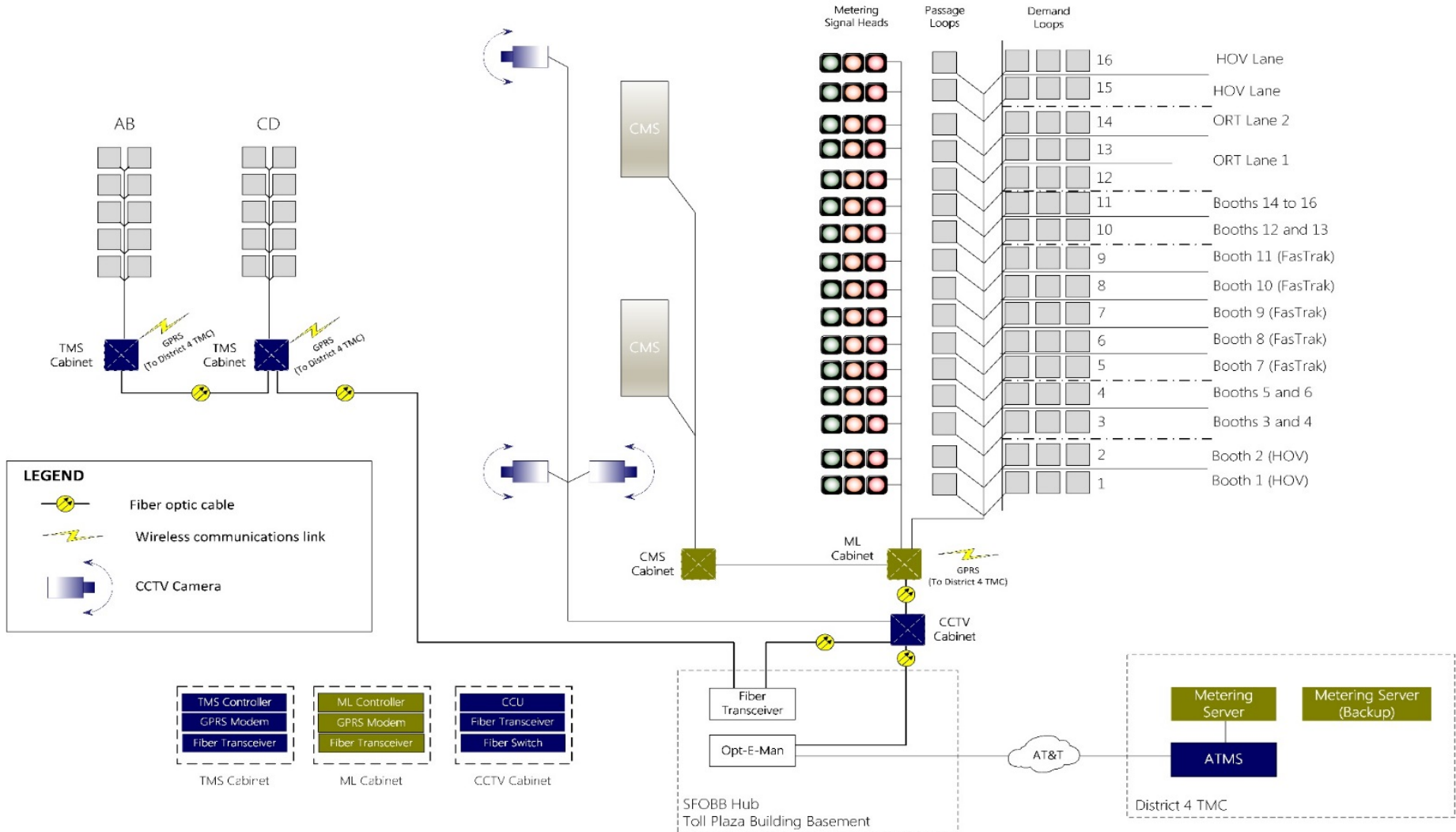



## Proposed System Elements

